

# Plena Universal Pre-amplifier



Security Systems

en | Installation and Operating Manual  
LBB 1920

**BOSCH**



## Important safeguards

- 1 Read instructions - All the safety instructions for use should be read before the system is operated.
- 2 Retain instructions - The safety instructions and instructions for use should be retained for future reference.
- 3 Heed warnings - All warnings on the unit and in the operating instructions should be adhered to.
- 4 Follow instructions - All operating instructions and instructions for use should be followed.
- 5 Cleaning - Unplug system units from the mains outlet before cleaning. Do not use liquid cleaners or aerosol cleaners. Use a damp cloth for cleaning.
- 6 Attachments - Do not use attachments not recommended by the product manufacturer as they may cause hazards.
- 7 Water and Moisture - Do not use this unit near water, for example near a bathtub, washbowl, kitchen sink, or laundry basket, in a wet basement, near a swimming pool, in an unprotected outdoor installation or any area which is classified as a wet location.
- 8 Accessories - Do not place this unit on an unstable stand, tripod, bracket or mount. This unit may fall, causing serious injury to a person and serious damage to the unit. Use only a stand, tripod, bracket or mount recommended by the manufacturer, or sold with the product. Any mounting of the unit should follow the manufacturer's instructions, and should use a mounting accessory recommended by the manufacturer. An appliance and cart combination should be moved with care. Quick stops, excessive force, and uneven surfaces may cause the appliance and cart combination to overturn.
- 9 Ventilation - Openings in the enclosure, if any, are provided for ventilation and to ensure reliable operation of the unit and to protect it from overheating. These openings must not be blocked or covered. The unit should not be placed in a built-in installation unless proper ventilation is provided or the manufacturer's instructions have been adhered to.
- 10 Power sources - Units should be operated only from the type of power source indicated on the marking label. If you are not sure of the type of power supply you plan to use, consult your appliance dealer or local power company. For units intended to operate from battery power, or other sources, refer to the "Installation and User Instructions".
- 11 Grounding or polarisation - This unit may be equipped with a polarised alternating current line plug (a plug having one blade wider than the other). This plug will fit into the power outlet only one way. This is a safety feature. If you are unable to insert the plug fully into the outlet, try reversing the plug. If the plug still fails to fit, contact your electrician to replace your obsolete outlet. Do not defeat the safety purpose of the polarised plug. Alternatively, this unit may be equipped with a 3-wire grounding type plug having a third (grounding) pin. This plug will only fit into a grounding-type power outlet. This is a safety feature. If you are unable to insert the plug into the outlet, contact your electrician to replace your obsolete outlet. Do not defeat the safety purpose of the grounding-type plug.
- 12 Power-Cord Protection - Power supply cords should be routed so that they are not likely to be walked on or pinched by items placed upon or against them, paying particular attention to cords and plugs, convenience receptacles, and the point where they exit from the appliance.
- 13 Overloading - Do not overload outlets and extension cords as this can result in a risk of fire or electrical shock.
- 14 Object and Liquid Entry - Never push objects of any kind into this unit through openings as they may touch dangerous voltage points or short-out parts that could result in a fire or electric shock. Never spill liquid of any kind on the unit.
- 15 Servicing - Do not attempt to service this unit yourself as opening or removing covers may expose to dangerous voltage or other hazards. Refer all servicing to qualified service personnel.
- 16 Damage Requiring Service - Unplug the unit from the outlet and refer servicing to qualified service personnel under the following conditions:
  - When the power-supply cord or plug is damaged.
  - If liquid has been spilled, or objects have fallen into the unit.
  - If the unit has been exposed to rain or water.
  - If the unit does not operate normally by following the instructions for use. Adjust only those controls that are covered by the instructions for use, as an improper adjustment of other controls may result in damage and will often require extensive work by a qualified technician to restore the units to their normal operation.
  - If the unit has been dropped or the unit has been damaged.
  - When the unit exhibits a distinct change in performance; this indicates a need for service.
- 17 Replacement Parts - When replacement parts are required be sure the service technician has used replacement parts specified by the manufacturer or parts which have the same characteristics as the original part. Unauthorised substitutions may result in fire, electric shock or other hazards.
- 18 Safety Check - Upon completion of any service or repairs to the units, ask the service technician to perform safety checks to determine that the unit is in proper operating condition.
- 19 Lightning - For added protection of the units during a lightning storm, or when it is left unattended and unused for long periods of time, unplug it from the wall outlet and disconnect the cable system. This will prevent damage to the unit due to lightning and power-line surges.

## About this manual

This manual provides all the information required to install and operate the unit.

### Conventions

**Warning**

Follow these instructions to prevent personal injury.

**Caution**

Follow these instructions to prevent damage to the equipment.

**Note**

Read these instructions for tips and other useful information.

## Safety precautions

**Warning**

Do not open the unit when it is connected to the mains. The unit contains non-insulated parts, which can cause electric shock.

**Caution**

There are no user-serviceable parts inside the unit. Service must be done by qualified personnel.

## Table of contents

Important safeguards.....	3
About this manual .....	4
Safety precautions.....	4
Table of contents .....	5
1 About the equipment .....	7
1.1 Controls and connections (front) .....	8
1.2 Controls and connections (rear) .....	8
2 Internal settings .....	9
2.1 Priority mode setting .....	9
2.2 Channel settings .....	9
2.2.1 Microphone or Line input .....	9
2.2.2 Mic/Aux input selection .....	9
2.2.3 Speech filter on/off .....	9
2.3 Setting emergency, insertion or cascade .....	10
3 Installation in rack .....	11
4 External settings and connections .....	12
4.1 Connect the DC supply (battery) .....	12
4.2 Connect a microphone or line-level source .....	13
4.3 Insertion or Cascade connection .....	14
4.4 Connect a Booster amplifier or System pre-amplifier .....	14
4.5 Connect an emergency input line .....	15
5 Operation .....	16
5.1 Set Line input volume, treble and bass .....	16
5.2 Line monitoring .....	16
6 Technical data .....	17
6.1 Electrical .....	17
6.2 Performance .....	17
6.3 Inputs .....	17
6.4 Outputs .....	18
6.5 Interconnection .....	18
6.6 Relays .....	18
6.7 Environmental conditions .....	18
6.8 General .....	18



# 1 About the equipment

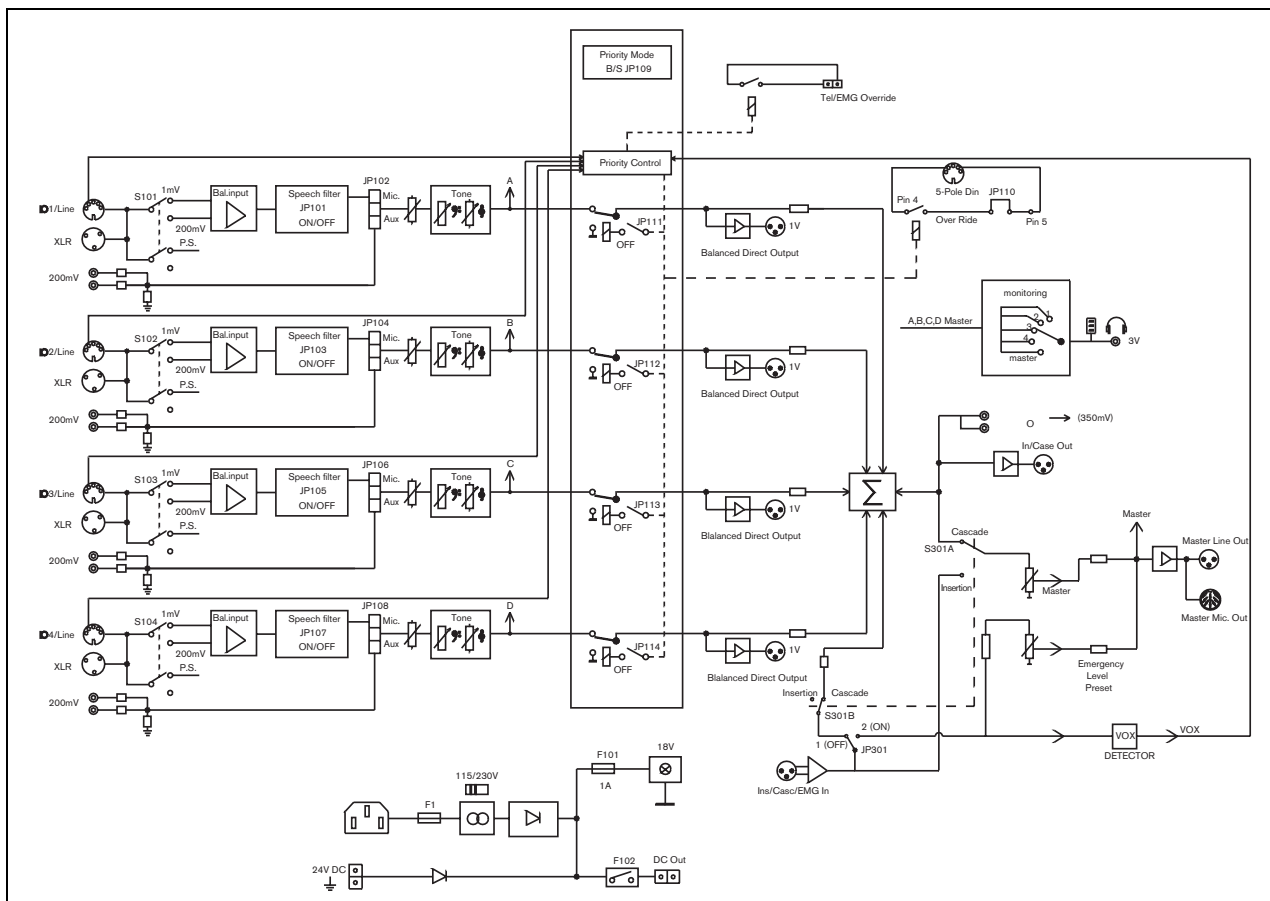

Figure 1.1

The Plena Universal Amplifier is a mono mixer amplifier with 4 input channels. Each channel has 3 possible input connections and a direct XLR output. You can adjust volume and tone level for each channel. The 4 input channels and the cascade input are mixed to one master signal. This master signal is available on the XLR and DIN output (mic. level). Additional outputs are the tape out and cascade out. All pre-amplifier channels and the master output can be monitored with a headphone.

All pre-amplifier channels and the master output can be monitored with a headphone.

## 1.1 Controls and connections (front)

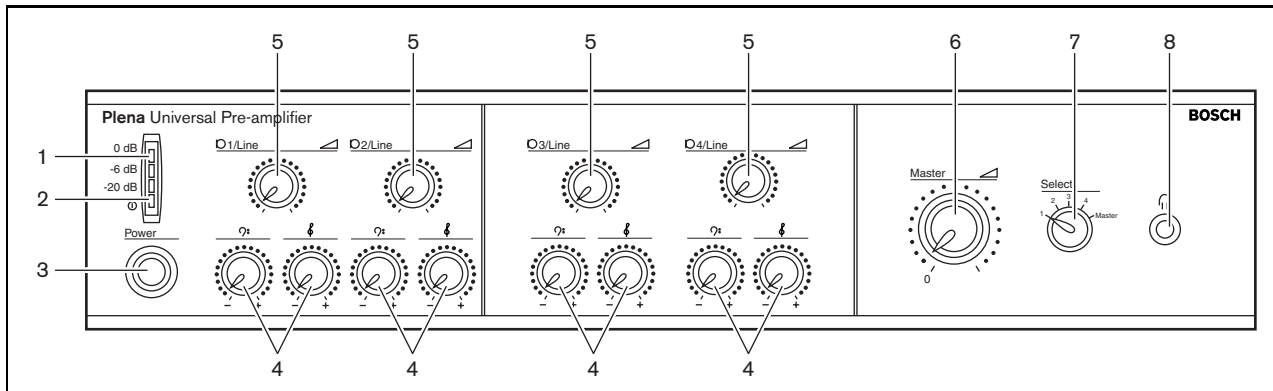

Figure 1.2

- |                                   |                                   |
|-----------------------------------|-----------------------------------|
| 1 VU meter (LED bar)              | 5 Volume, channel 1 to 4          |
| 2 Power on indication LED (green) | 6 Master volume                   |
| 3 Power on/off                    | 7 Channel selection for headphone |
| 4 Tone control, channel 1 to 4    | 8 Headphone connection            |

## 1.2 Controls and connections (rear)

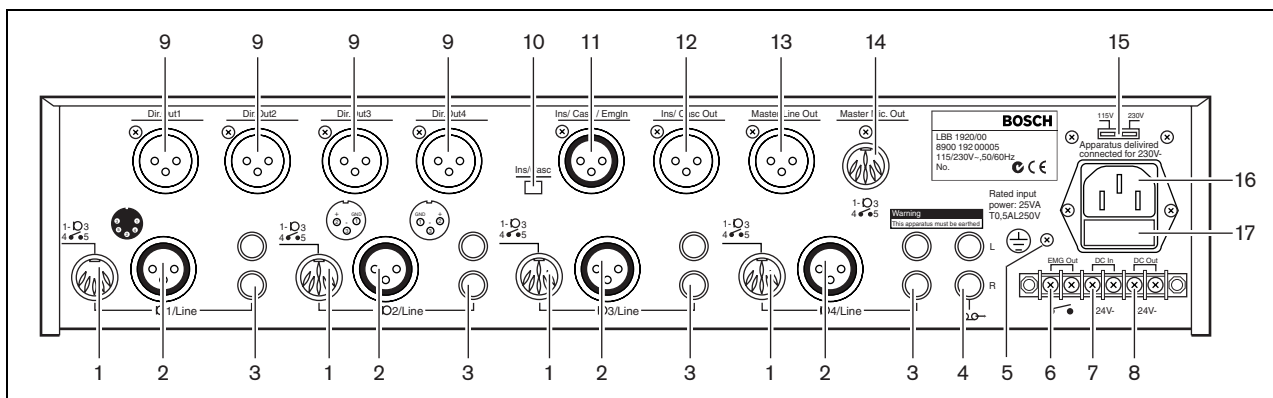

Figure 1.3

- |   |   |
|---|---|
| 1 DIN (priority) input, channel 1 to 4  | 10 Insertion/ cascade switch            |
| 2 XLR input, channel 1 to 4             | 11 Insertion/ cascade / emergency input |
| 3 Cinch input, channel 1 to 4           | 12 Insertion/ cascade output            |
| 4 Tape output (Cinch)                   | 13 Master Line output (XLR)             |
| 5 Earth connection screw                | 14 Master Mic output (DIN, priority)    |
| 6 Emergency relay output (terminal)     | 15 Mains voltage 115/ 230 V switch      |
| 7 24 V DC backup power input (terminal) | 16 Mains socket                         |
| 8 24 V DC output (terminal)             | 17 Mains fuse                           |
| 9 XLR for direct output, channel 1 to 4 |   |

## 2 Internal settings

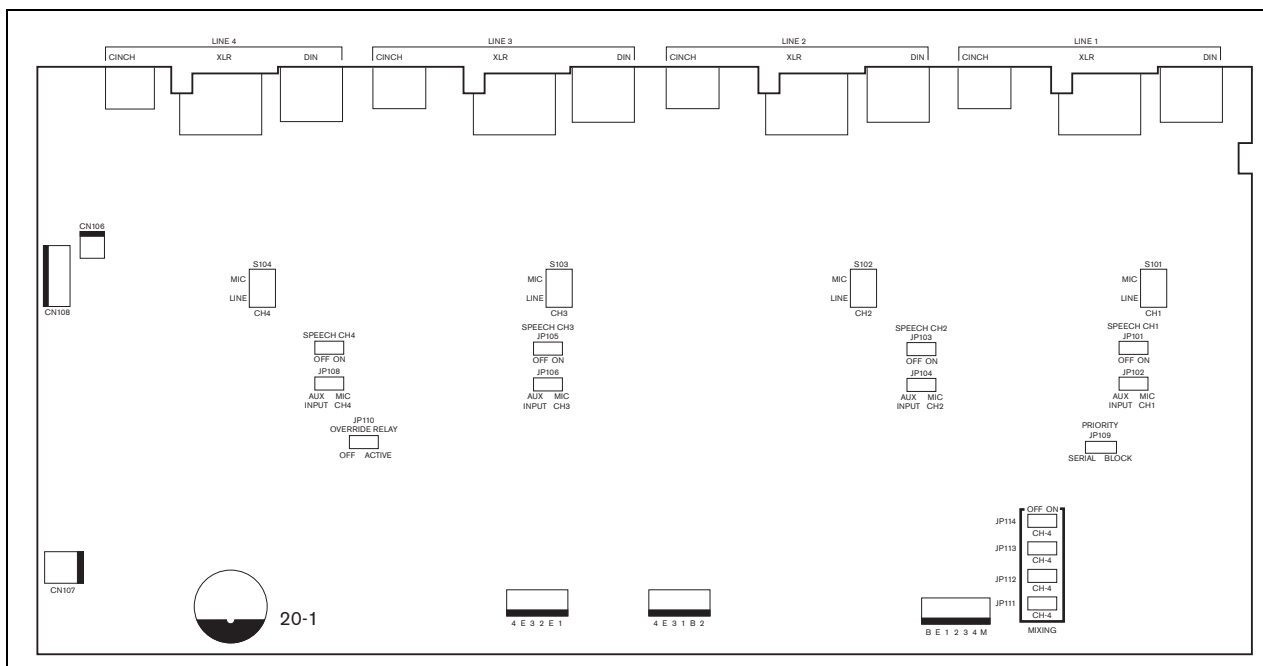

Figure 2.1

### 2.1 Priority mode setting

The priority mode can be set with jumper JP109 to serial or blocking mode. You can activate the mixing mode for channel 1 to 4 with jumpers JP111 to JP114. The jumper JP110 enables or disables the priority override contact for the 4 input channels. This contact is available on the Master Mic output to pass through priorities.

- Serial mode(default) : Channel 1 has the highest priority and channel 4 the lowest.
- Blocking mode : The first activated input channel has the highest priority and blocks all other channels.
- Mixing mode : The channel is mixed to the master output irrespective of priority.

### 2.2 Channel settings

#### 2.2.1 Microphone or Line input

If you connect a microphone to an input channel, the switch (S101 to S104) must be in the Mic position. This setting activates the Phantom power supply. If you connect a line level source the switch (S101 to S104) must be set in the line position.

#### 2.2.2 Mic/Aux input selection

If you use the 5-pole DIN or the 3-pole XLR input of a channel, the corresponding jumper (JP102, JP104, JP106 or JP108) must be in the MIC position. If you use the Cinch input the jumper must be in the AUX position.

#### 2.2.3 Speech filter on/off

Each channel has a speech filter that can be enabled or disabled with the corresponding jumper (JP101, JP103, JP105, and JP107). The speech filter improves speech intelligibility by cutting off the lower frequencies.

## 2.3 Setting emergency, insertion or cascade

The functionality of the insertion/cascade/emergency input is determined with jumper JP301 and the 'Ins/Casc' switch at the back of the unit.

Input/output used for	Jumper JP301	Switch
Insertion	OFF	INS
Cascade	OFF	CASC
Emergency	ON	CASC



### Note

If you use the emergency option, the emergency volume can be set with VR301. This volume is not affected by the master volume.

### 3 Installation in rack

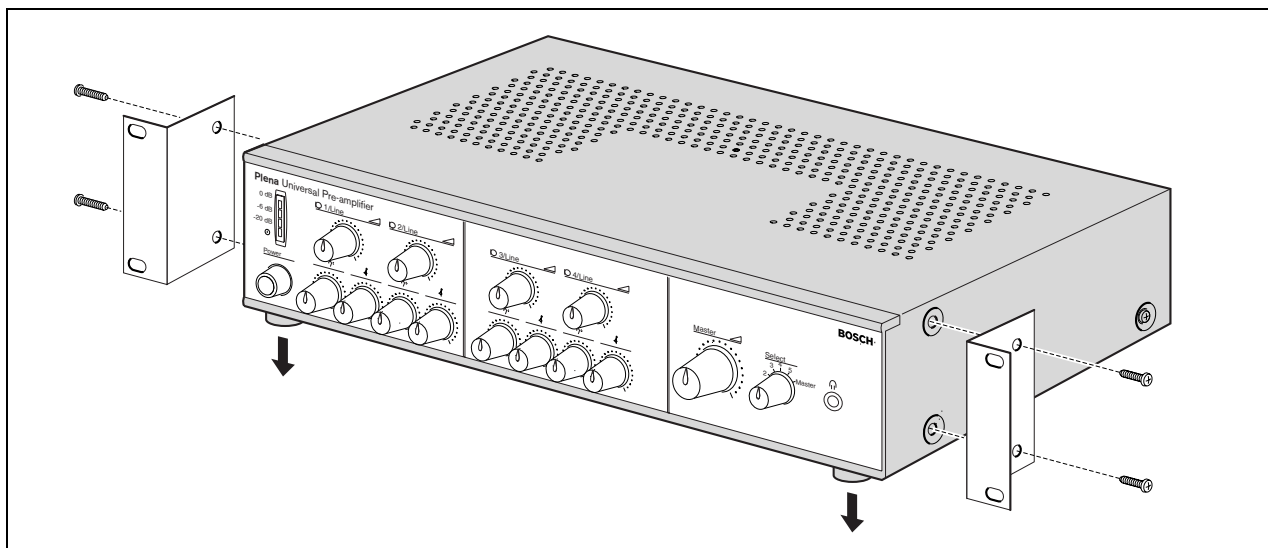

Figure 3.1

The universal pre-amplifier is delivered for table-top use, but you can mount it in a 19" rack. If you mount the pre-amplifier in a rack, you must:

- use the mounting brackets delivered with the unit.
- remove the 4 feet from the bottom of the unit. (Without the feet the unit is 2U high).

## 4 External settings and connections

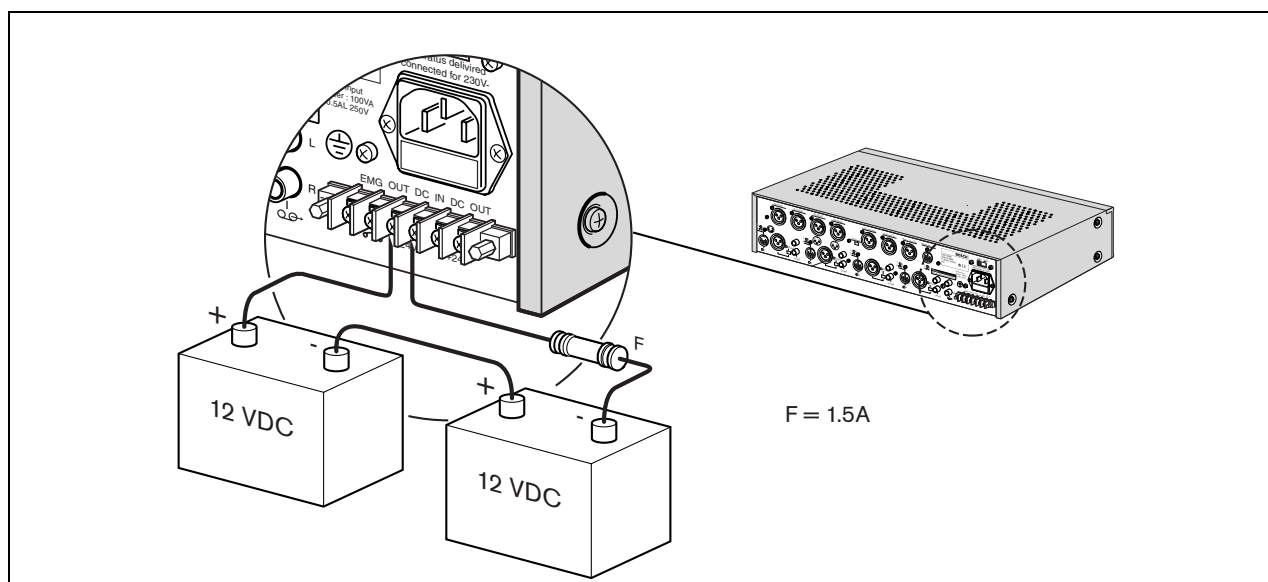

Figure 4.1

### 4.1 Connect the DC supply (battery)

The universal pre-amplifier has a 24 Vdc input (terminal screw), which you can use to connect a back up power supply, e.g. batteries. You can earth the unit to increase the electrical stability of the system. The unit is protected against reversal of the battery polarity.



#### Caution

The connection cable must have an in-line fuse. Use the type of fuse as mentioned in the illustration.

## 4.2 Connect a microphone or line-level source

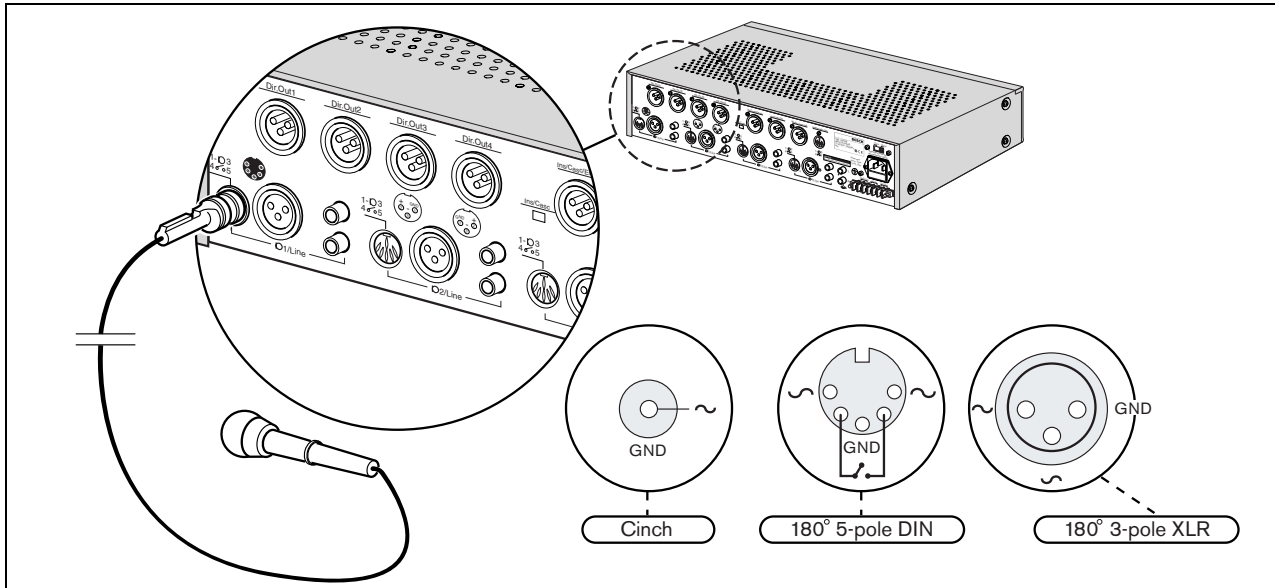

Figure 4.2

All channels have 3 possible inputs, use one of these inputs to connect a microphone or a line-level source. The XLR and DIN input are balanced, the stereo Cinch input is unbalanced and converted to mono. If you use an input make sure that the internal switch settings are correct (refer to §2.2).



### Note

If you want to use the priority feature, you must use a microphone or line-level source with a priority contact on pin 4 and 5 of the 5-pole DIN plug.

### 4.3 Insertion or Cascade connection

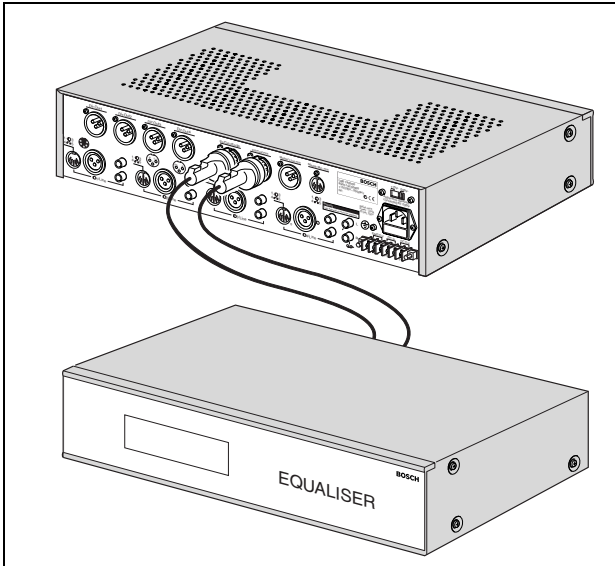

Figure 4.3

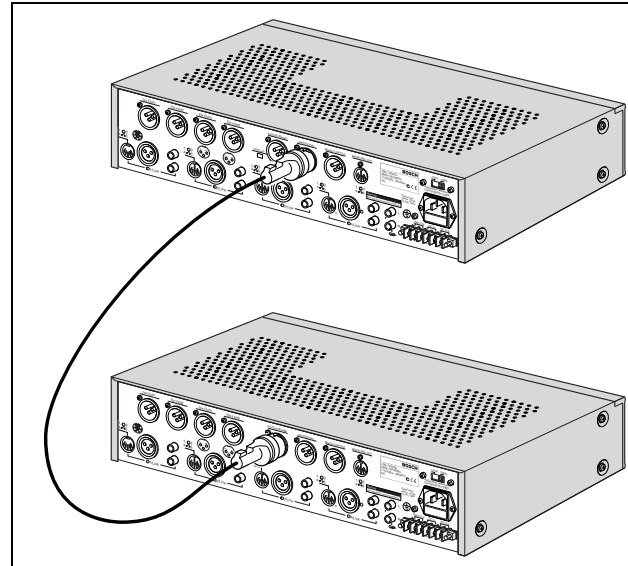

Figure 4.4

If you use the insertion or cascade mode, you must set the 'Ins/Casc' switch, on the rear, in the correct position. The insertion mode can be used to connect an external sound-processing device, e.g. an equaliser. To increase the number of input channels, you must use the cascade mode to link pre-amplifiers. E.g. with 2 pre-amplifiers, the second preamplifier has 8 channels on its master output (4 channels from the first pre-amplifier and 4 channels of its own).

### 4.4 Connect a Booster amplifier or System pre-amplifier

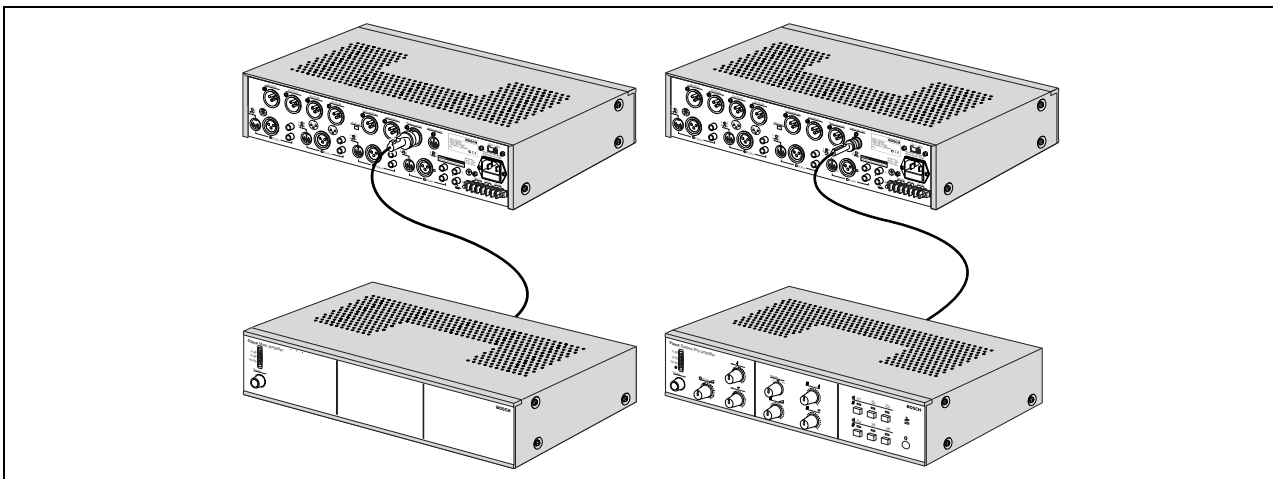

Figure 4.5

The master output and/or the direct outputs can be connected to a Plena Booster to amplify the signal to loudspeaker level. You can also use the outputs to connect the universal pre-amplifier to the System pre-amplifier or other equipment. The Master Mic output (DIN) has a priority relay contact on pin 4 and 5. This relay is activated when a priority contact of one of the inputs is closed.

## 4.5 Connect an emergency input line

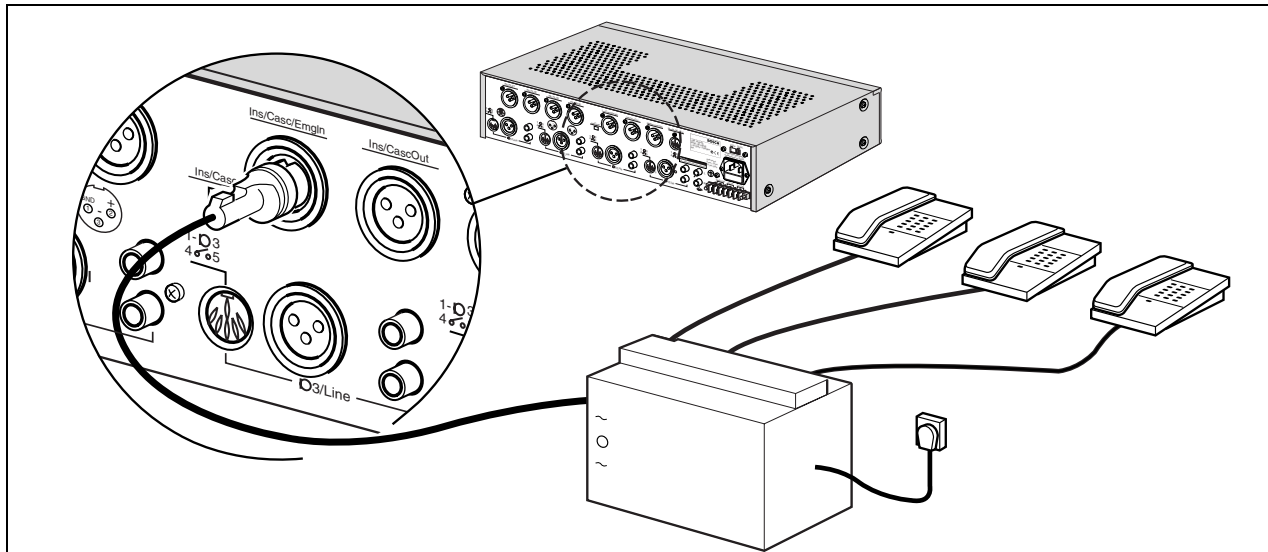

Figure 4.6

You can use this input for emergency announcements and/or signals. This line is activated when the signal is above a certain threshold (VOX). When the line is activated it has the highest priority and overrules all input channels. The emergency line has its own internal volume control and is not affected by the master volume. To set the emergency volume, refer to §2.3. If you use the emergency input make sure that the internal settings are correct (refer to §2.2).



### Note

The emergency input has a 24 V relay output (screw terminal), which is activated on the VOX of the input. An additional 24 Vdc output (screw terminal) is available to power external relays.

## 5 Operation

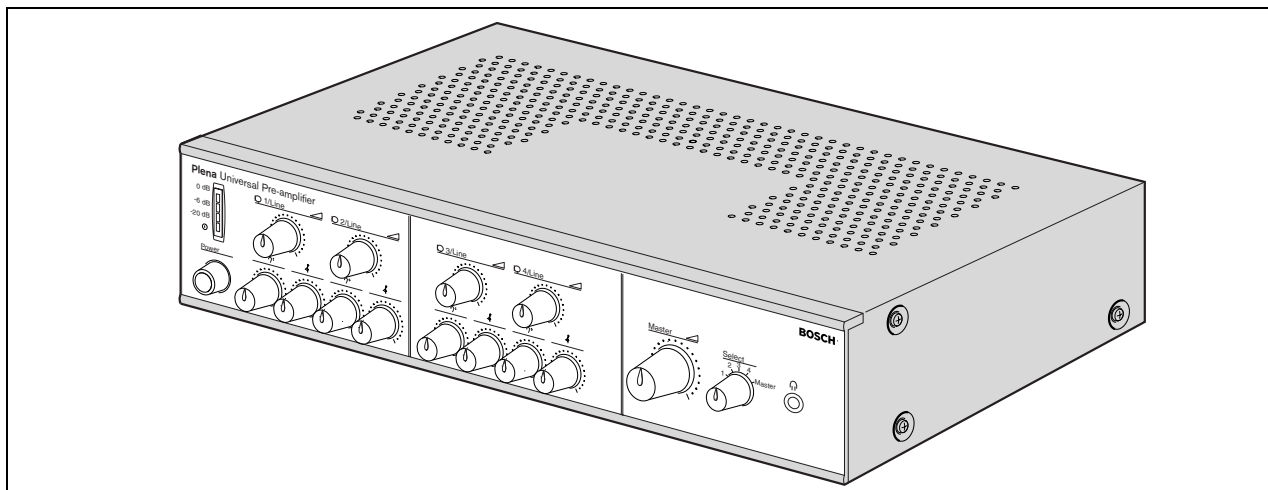

Figure 5.1

### 5.1 Set Line input volume, treble and bass

You can adjust the volume, treble and bass for each channel by turning the corresponding knobs. To change the overall volume you must turn the 'Master' volume knob.

### 5.2 Line monitoring

The line monitoring can be used to listen to a single channel or the master channel. To do so connect a headphone at the front of the pre-amplifier. Use the 'Select' switch to select a channel.



#### Note

The VU-meter always shows the volume for the selected channel.

## 6 Technical data

### 6.1 Electrical

Mains voltage	230/115 Vac, $\pm 15\%$ , 50/60 Hz
Max mains power consumption	25 VA
Battery voltage	24 Vdc, $+20\%$ / $-10\%$
Max battery current	1A

### 6.2 Performance

Frequency response	50 Hz - 20 kHz (+1/-3 dB)
Distortion	<0.5 %
Bass control	$\pm 10$ dB at 100 Hz
Treble control	$\pm 10$ dB at 10 kHz
Line separation at 1 kHz	>70 dB
Priority mute	>40 dB

### 6.3 Inputs

#### Mic/Line inputs 1-4 (3-pin XLR/5-pin DIN, balanced)

Sensitivity	1 mV (microphone), 200 mV (line)
Impedance	>1 kOhm (microphone), >5 kOhm (line)
S/N (flat at max volume)	>63 dB (microphone), >70 dB (line)
S/N (flat at min volume/muted)	>75 dB
CMRR	>40 dB (50 Hz - 20 kHz)
Headroom	>25 dB
Speech filter	-3 dB at 315 Hz, high-pass, 6 dB/oct
Phantom power supply	16 V via 1.2 kOhm, in microphone mode only

#### Line inputs 1-4 (Cinch, unbalanced, stereo converted to mono)

Sensitivity	200 mV
Impedance	22 kOhm
S/N (flat at max volume)	>70 dB
S/N (flat at min volume/muted)	>75 dB
Headroom	>25 dB

## 6.4 Outputs

### Direct outputs 1-4 (3-pin XLR, balanced)

Nominal level	1 V
Impedance	<100 Ohm

### Master output (3-pin XLR, balanced)

Nominal level	1 V
Impedance	<100 Ohm

### Master output (5-pin DIN, balanced)

Nominal level	4 mV (microphone level)
Impedance	<100 Ohm

### Tape output (Cinch, 2x mono)

Nominal level	350 mV
Impedance	<1 kOhm

### Headphone output (6.3 mm jack stereo, signal mono)

Nominal level	3 V
Impedance	<100 Ohm

## 6.5 Interconnection

### Interconnection/emergency input (3-pin XLR, balanced)

Sensitivity	200 mV (interconnection) 100 mV - 1 V adjustable (emergency)
Impedance	>10 kOhm
VOX threshold	45 mV (emergency)

### Interconnection output (3-pin XLR, balanced)

Nominal level	200 mV
Impedance	<100 Ohm

## 6.6 Relays

Priority relay contacts	30 V, 1 A
Emergency relay contacts	30 V, 1 A
DC supply output voltage	24 V, 250 mA max

## 6.7 Environmental conditions

Operating temperature range	-10 to +55 °C
Storage temperature range	-40 to +70 °C
Relative humidity	<95 %

## 6.8 General

EMC emission	acc. to EN 55103-1
EMC immunity	acc. to EN 55103-2
Dimensions	100 x 430 x 270 mm (19" wide, 2U high)
Weight	approx. 5 kg



For more information visit  
[www.boschsecuritysystems.com](http://www.boschsecuritysystems.com)

© Bosch Security Systems B.V.  
Data subject to change without notice  
2003-09 | 3922 988 99482en

**BOSCH**