

SM 25B SOUND MANAGEMENT SYSTEM

SM 25B SOUND MANAGEMENT

SM 25B Modular Sound Management System

Contents

1. Introduction

SM 25B modular sound management system.	1.1
Type number overview	1.2

2. System parameters

General system parameters.	2.1
Mixing systems	2.1
Call systems	2.1
Power Consumption Factor (PCF)	2.2
General configuration lines	2.3

3. Boosters

Introduction	3.1
Booster Carrier Frame	3.1
60 W, 120 W and 240 W Boosters and Booster Frames	3.3
60 + 120 W Dual Booster Frame	3.4
Block diagrams	3.5
Technical data	3.7

4. Power Supply Module

Introduction	4.1
Power Supply Module	4.1
Block diagram	4.2
Technical data	4.2

5. Call Station Units

Introduction	5.1
Call Station Basic	5.2
Technical data	5.2
Call Station Extension	5.3
Technical data	5.3

6. Input Modules

Introduction	6.1
Mixing Input Modules	6.1
General Mixing Module	6.2
Mixing Input Module	6.3
Technical data GMM and MIX	6.3
Block diagrams GMM and MIX	6.4
Call Station Module	6.6
Technical data	6.7

7. Sound modules

Introduction	7.1
Alarm Routing Module	7.2
Technical data	7.2
ARM Block diagram	7.3
Recordable Message Module	7.4
Technical data	7.4
RMM Block diagram	7.5
Tuner Module	7.6
Technical data	7.7
TUM Block diagram	7.7

SM 25B SOUND MANAGEMENT

SM 25B Modular Sound Management System

8. Output modules

Introduction	8.1
Zone Relay Module	8.2
Technical data	8.2
Manual Zone Switch Module	8.3
Technical data	8.3
Block diagrams ZRM and MZS	8.4

9. Ancillary equipment

Module Extension Frame	9.1
Frame Interconnection Module	9.1
Booster Connection Board	9.1

10. Accessories

Table-Top Set	10.1
Hand-Grip Set	10.1
Blank Panel Set	10.1
Call Station Connection cable	10.2
Call Station Cable Reel (100 m)	10.2

11. Configuration examples

2-input mixing amplifier	11.1
4-input mixing amplifier with manual zone selection	11.1
10-input mixing amplifier	11.2
Single-channel call amplifier	11.3
Single-channel call system with manual zone selection	11.4
2-channel call amplifier with automatic zone selection	11.5

12. Index

Alphanumeric index	12.1
Type number index	12.2

SM 25B SOUND MANAGEMENT

I. Introduction

SM 25B Modular Sound Management System

SM 25B is a modular audio switching and routing system with a range of input modules, output modules and Booster Amplifiers that are combined and configured according to specific application requirements. SM 25B can automatically route audio to up to 12 loudspeaker zones, or can be used with a Manual Zone Switch module to provide manual routing to any number of zones (subject to system limits).

Booster Frames and Amplifiers

Four Booster Frames form the basis of SM 25B. Each contains one single or one dual amplifier, a power supply, interconnection wiring and space for up to six single-width modules. The Booster Frames are suitable for 19-inch rack mounting or table top use. There is also a choice of three half 19-inch Booster Amplifiers for additional power requirements or for alternative configurations. Because the Booster Frames and Amplifiers use single mode power supplies (SMPS), they adhere to future mains pollution requirements. The choice of modules is dictated by the specific system requirements, allowing the SM 25B system to be configured for a particular application. If more than six modules are required, a Module Extension Frame provides housing for an additional 11 single-width modules (or 10 if a Power Supply Module is used).

'Plug-and-play' simplicity

SM 25B modules are 'hardware configurable', using switches and jumpers on the printed circuit boards of SM 25B system elements. The functionality is configured for specific requirements, such as chime tone preceding announcements, background music, priority level, and so on. Although all SM 25B system elements are hardware configurable, they are delivered with factory defaults in a standard configuration that functions as a basic sound management system when installed. This is the 'plug-and-play' mode.

SM 25B applications

Typical applications for SM 25B include shopping malls, department stores, hotels, railway and bus stations, small airports, industrial and commercial sites, and leisure and sport facilities. SM 25B provides audio mixing functions, call routing to various zones or a combination of call and mixing.

SM 25B call configurations

A basic call configuration comprises a Booster Frame, Call Station Module and a number of Call Stations. The functionality of each Call Station may be extended using one or two Call Station Extensions. The output may be manually routed to loudspeaker zones using a Manual Zone Switch or, upon (pre-)selection from a Call Station, can be routed using a Zone Relay Module. An Alarm Routing Module (ARM) can be used for alarm/time signal generation.

SM 25B mixing configurations

A basic mixing configuration comprises a Booster Frame and a General Mixing Module (with two inputs). For more inputs, MIXing input modules are added. The output may be manually routed to loudspeaker zones using a Manual Zone Switch module.

SM 25B Helpsell

There is a software program available to help select which SM 25B modules are required for different configurations and public address requirements. The SM 25B Helpsell can be obtained on request from Philips, or can be downloaded from www.philipscsi.com.

SM 25B SOUND MANAGEMENT

I. Introduction

Type number overview

Below is an outline of all SM 25B products, type numbers and code names. Specific, detailed information for each type number is found in the relevant chapter of this brochure.

Functional index

Product description	Code	Type number	Page
Boosters			
60 W Booster Frame	F60	LBB 2006/00	3.3
120 W Booster Frame	F120	LBB 2012/00	3.3
60 + 120 W Booster Frame	F180D	LBB 2018/00	3.4
240 W Booster Frame	F240	LBB 2024/00	3.3
60 W Booster Amplifier	B60	LBB 2106/00	3.3
120 W Booster amplifier	B120	LBB 2112/00	3.3
240 W Booster Amplifier	B240	LBB 2124/00	3.3
Power Supply Module	PSM	LBB 2502/10	4.1
Booster Carrier Frame	BCF	LBB 2100/00	3.1
Mixing input modules			
General Mixing Module	GMM	LBB 2510/20	6.2
Mixing Input Module	MIX	LBB 2516/10	6.3
Call input modules			
Call Station Module	CSM	LBB 2511/10	6.6
Tuner Module			
Tuner Module	TUM	LBB 2521/10	7.6
Alarm Routing Module			
Alarm Routing Module	ARM	LBB 2540/10	7.2
Recordable Message Module			
Recordable Message Module	RMM	LBB 2541/10	7.4
Loudspeaker zone switching modules			
Manual Zone Switch	MZS	LBB 2550/00	8.3
Zone Relay Module	ZRM	LBB 2551/10	8.2
Call Stations			
Call Station Basic	CS-B	LBC 2500/10	5.2
Call Station Extension	CX-B	LBC 2502/10	5.3
Ancillary equipment			
Module Extension Frame	MXF	LBB 2500/00	9.1
Frame Interconnection Module	FIM	LBB 2505/10	9.1
Booster Connection Board	BCB	LBB 2503/00	9.1
Accessories			
Hand-grip Set	HGS	LBC 1501/00	10.1
Table-top Set	TTS	LBC 1500/00	10.1
Blank Panel Set	BPS	LBC 1502/00	10.1
Call Station Connection Cable	CCC	LBC 1510/10	10.2
Call Station Cable (100 m reel)	CCR	LBC 1520/10	10.2

SM 25B SOUND MANAGEMENT

2. System Parameters

General system parameters

SM 25B is a modular two-channel sound management system for PA applications.

Audio channels

SM 25B has two audio channels, one for call and one for background music. The Call Station Module (CSM) has inputs for both call and music channels. The General Mixing Module (GMM) only has access to the call channel.

Maximum number of plug-in modules

SM 25B Booster Frames house six single-width plug-in modules. A Module Extension Frame (MXF) houses 12 single-width plug-in modules. One position is always occupied by a Frame Interconnection Module (FIM), or, if extra power is required, two positions are occupied by a Power Supply Module (PSM). If a PSM is present, a FIM is unnecessary. The maximum number of modules in a system is limited by the available power from Booster Frame's built-in power supply module and PSM (if present).

Priority (announcement)

The SM 25B system has five selectable priority levels for both microphones and Call Stations. Priority level 5 is the highest, 1 is the lowest. Microphones inputs without priority status are mixed. Priority microphones in a call system always make an 'all-call' announcement (to all zones). A Call Station must have a priority level assigned.

System Functionality

SM 25B makes three types of public address broadcasts:

- Call - all broadcasts made via a Call Station. It is possible to select which zone(s) a call is routed to.
- Announcement - all broadcasts made via a microphone input with a priority level (P1 to P5). Announcements are routed to all zones.
- Mix - all broadcasts made via a microphone or line input in mixing mode or mixing-on-demand mode. These broadcasts are routed to all zones.

Mixing systems

SM 25B has two mixing modules, the General Mixing Module (GMM) and the Mixing Input Module (MIX). These modules, per input, have two mixing modes and five priority announcement modes:

- mixing
- mixing-on-demand
- priority (announcement)

Mixing modes

The 'mixing mode' is for all microphone types and for all line inputs. The mixing-on-demand mode requires microphones with remote switching contacts.

Call systems

SM 25B configurations can have one or more call system input modules. The Call Station Module (CSM) connects up to nine Call Stations or Call Station Extensions and one music source to a Booster Frame. Call Stations can be connected in a 'daisy chain' configuration that is very cost effective as it uses less cable. Daisy chains can be connected to one or both CSM connectors. A 'ring' configuration using both CSM connectors is also possible. This means that in the event of cable breakage, the Call Stations will still function. Alternatively, a 'star' configuration using both CSM connectors is possible. There are two output modules, the Zone Relay Module (ZRM) for automatic zone selection, and the Manual Zone Switch (MZS) for manual zone selection.

Loudspeaker zones

Up to 12 loudspeaker zones are possible with automatic zone selection using Call Stations (CS-B), Call Station Extensions (CX-B), a Call Station Module (CSM) and Zone Relay Modules (ZRM). More zones are possible using the Manual Zone Switch (MZS), but not in combination with automatic selection.

SM 25B SOUND MANAGEMENT

2. System Parameters

Maximum number of Call Stations

A single CSM can connect a total of up to nine Call Stations or Call station Extensions. The CSM supplies power to the Call Stations and Call Station Extensions via the connection cable. The CSM is provided with two connectors for Call Stations. They are internally connected in parallel and are functionally identical.

Each Call Station and Call Station Extension has a Power Consumption Factor (PCF) of 1. A CSM can deliver 9 PCF. Therefore, the combined PCF of Call Stations and Call Station Extensions connected to one CSM must not exceed 9.

Maximum distance

Two Call Station units may be situated up to 1 km from the CSM when using a cable with the recommended specifications. Up to nine Call Station units can be connected to a CSM if linked in a loop-through or branched configuration. The figure below shows the relationship between length of standard recommended cable and number of Call Station units connected.

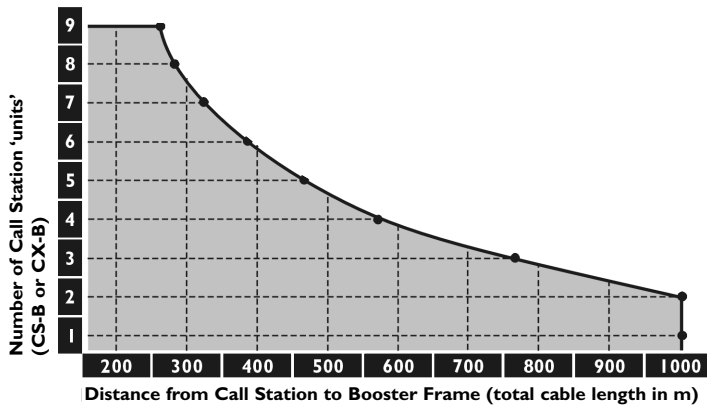

Power Consumption Factor (PCF)

A Booster Frame has 0.5 A available for powering modules, Call Stations and Call Station Extensions. The power consumption for all modules is given as a 'Power Consumption Factor' (PCF). One PCF requires 20 mA, therefore a Booster Frame can deliver 25 PCF. The total PCF for all modules, Call Stations and Call Station Extensions must not exceed 25 PCF. A Power Supply Module can supply an additional 35 PCF (0.7 A), if required.

PCF requirements for SM 25B modules

Ref	Description	PCF
ARM	Alarm Routing Module	2
BCB	Booster Connection Board	0
CS-B	Call Station	1
CSM	Call Station Module	3
CX-B	Call Station Extension	1
FIM	Frame Interconnection Module	0
GMM	General Mixing Module	4
MIX	Mixing Input Module	3
MXF	Module Extension Frame	0
MZS	Manual Zone Switch	0
RMM	Recordable Message Module	3.5
TUM	Tuner Module	3.5
ZRM	Zone Relay Module	2

SM 25B SOUND MANAGEMENT

2. System Parameters

General configuration lines

The following is an overview of specific requirements for SM 25B configurations:

- For mixing configurations, one GMM is required per Booster Frame and MXF
- One CSM is required for up to nine Call Stations and Call station Extensions
- One FIM (or PSM) is required for each MXF
- Output modules (ZRM and MZS) should be inserted on the right-hand side of the Booster Frame (viewed from the front)
- Input modules (GMM and MIX) should be inserted on the left-hand side of the Booster Frame (viewed from the front)
- One empty module position must be left between output modules (MZS and ZRM) and input modules (GMM and MIX)
- The CSM, ARM or TUM may also be positioned between a GMM (or MIX) and ZRM (or MZS, ARM or TUM)
- Unused module positions in a Booster Frame must be covered with a blank panel (a set of three blank panels are available in the LBC 1502/00 Blank Panel Set). This ensures that the Booster Frame (or MXF) is properly ventilated.

SM 25B SOUND MANAGEMENT

3. Boosters

Type no.	Description	Code	Page
LBB 2006/00	60 W Booster Amplifier	F60	3.3
LBB 2012/00	120 W Booster Amplifier	F120	3.3
LBB 2018/00	60 W and 120 W Booster Amplifier	F180D	3.4
LBB 2024/00	240 W Booster Amplifier	F240	3.3
LBB 2106/00	60 W Half 19-inch Booster Amplifier	B60	3.3
LBB 2112/00	120 W Half 19-inch Booster Amplifier	B120	3.3
LBB 2124/00	240 W Half 19-inch Booster Amplifier	B240	3.3
LBB 2100/00	Booster Carrier Frame	BCF	3.1

Introduction

Three Booster Frames with single amplifier and power supply are available. A dual-amplifier Booster Frame is also available for two-channel call/music systems. It features separate call and music amplifiers. All Booster Frames have space for six single-width plug-in modules.

Three half 19-inch Booster Amplifiers are also available. They provide amplifier power in sound management systems to supplement a Booster Frame (or Booster Amplifier). They also form an additional power source for SM 25B modules. A Booster Carrier Frame (BCF) is available separately to carry one or two Booster Amplifiers. In case only one booster is mounted in a BCF a Blind Panel Set (BPS) is needed for proper cooling.

System extension

If more than six modules are required in an SM 25B system, they are inserted in a Module Extension Frame (MXF) and connected to the Booster Frame via a Frame Interconnection Module (FIM) or Power Supply Module (PSM). Modules inserted into an MXF can be powered from the Booster Frame power supply or by a PSM. Refer to page 9.1. A Booster Frame can also be used if more power is required for the modules.

Built-in amplifier supervision

An error detected in the Booster Frame amplifier can activate a changeover relay to redirect the loudspeakers to the output of a back-up amplifier. A red 'error' LED on the front panel indicates a failure. A second relay contact is provided for activating e.g. an audible alarm or for paging technical support in the event of an amplifier or power failure. All relay contacts are accessible via the 12-pole ITT Cannon Trident connector on the rear panel.

Emergency back-up with a spare amplifier

To allow continued operation in the event of a call amplifier failure, spare SM 25B back-up amplifiers can be connected. In such configurations, loudspeakers connected to the main call amplifier's audio output are automatically re-routed to the audio output of the spare back-up amplifier when an error is detected in the main booster amplifier. Modules in the main Booster Frame can be powered by a spare back-up amplifier. For information on how to connect back-up amplifiers, refer to the SM 25B application notes.

Insertion

All booster amplifiers have insertion connector(s) on the rear panel to allow auxiliary audio equipment such as a graphic equaliser or Philips Profecta Acoustic Feedback Suppressor to be inserted between the pre-amplifier and power amplifier stages.

Interconnection

Single amplifier booster amplifiers have 'interconnection in' and 'interconnection out' connectors to allow them to be connected to other PA equipment (another booster amplifier for example). The 39 Vd.c. power supply is available on the 'interconnection in' connector to power modules in the main Booster Frame if used as a back-up amplifier. For more information on how to make these connections, refer to the SM 25B application notes.

SM 25B SOUND MANAGEMENT

3. Boosters

Call and music outputs

The internal call and music audio lines in the Booster Frame are provided with output connectors on the rear panel. This allows additional booster amplifiers to be connected.

Loudspeaker output

The power amplifier has a loudspeaker matching transformer with a choice of 50 V, 70 V or 100 V audio line outputs. Loudspeakers can be driven at full-power (100 V), half-power (70 V) or quarter-power (50 V).

Loudspeakers are connected via a 12-pole ITT Cannon Trident female connector on the rear panel. A male connector and ejector tool is supplied with each booster amplifier.

Plug-and-play functionality

Booster amplifiers are designed for 'plug-and-play' operation, with default settings that allow it to be used 'straight out of the box'. Many configurable functions are built in, and an overview of the configurable functionality is given below.

Configurable functionality

Booster amplifiers are configured for extra functionality using switches and jumpers on the PCBs. The following can be adjusted and/or selected:

- Call, Music or External audio input select to pre-amplifier (60 W, 120 W and 240 W booster amplifiers only)
- Pre-amplifier input sensitivity (0.5 V or 1 V)
- Insertion on/off
- Internal/external pilot tone (20 kHz)
- 39 V available on 'interconnection out' connector (60 W, 120 W and 240 W booster amplifiers only)
- Change-over on/off
- Pilot tone level
- Pilot tone on/off
- Volume control gain adjustment
- Loudspeaker output transformer voltage (100, 70 or 50 V)

System interconnection cable

Modules inserted into a Booster Frame or MXF are connected via a flexible system cable (16-pole IDC) that runs along the top of the housing. All positions in the Booster Frame are functionally identical.

Mains power supply

Booster amplifiers operate from a 220/240 V, 50/60 Hz mains supply. The transformer is thermally fused to prevent overheating. A 1.5 m mains cable is delivered with each unit, terminated at one end with an earthed 2-pole mains plug, and at the other with a CEE standard mains connector. A CEE mains connector is fitted on the rear panel.

Back-up DC supply

The booster amplifiers can also be powered by a 48 V d.c. supply via a 4-pole ITT Cannon Trident connector on the rear panel. This ensures all PA functions remain unaffected in the event of a mains power failure. The d.c. power connector also has a connection for a remote on/off switch. A spare female connector is supplied.

Mounting

SM 25B Frames are designed for 19-inch racks or can be housed in a robust Table-top Set (TTS), LBB 1500/00. For rack-mounted systems, the Frame enclosure is fitted with a sliding drawer system that allows it to be withdrawn from the rack for accessibility during service and installation. A Booster Carrier Frame (BCF) is also available for carrying one or two half 19-inch booster amplifiers.

SQ 45 emulation

An SM 25B booster amplifier can also emulate a Philips SQ 45 Booster Amplifier in SM 30 and SM 40 sound management systems. The LBB 2503/00 Booster Connection Board (BCB) is available for this application (refer to page 9.1).

SM 25B SOUND MANAGEMENT

3. Boosters

60 W, 120 W and 240 W Booster Frames and Booster Amplifiers (LBB 2006/00, LBB 2012/00 and LBB 2024/00, LBB 2106/00, LBB 2112/00, LBB 2124/00 (F60, F120, F240, B60, B120, B240))

- 60 W amplifier power (LBB 2006/00, LBB 2106/00)
- 120 W amplifier power (LBB 2012/00, LBB 2112/00)
- 240 W amplifier power (LBB 2024/00, LBB 2124/00)
- Housing for up to six single-width SM 25B modules (Booster Frames only).

Front panel controls and indicators

- Mains on/off switch
- Power indicator (green LED), indicates the presence of the mains power
- Booster error indicator (red LED), indicates booster amplifier malfunction
- Analogue VU meter, indicates the booster amplifier power amplifier output level

Front panel connectors

- Headphone stereo jack connector (internally wired for mono) for monitoring amplifier output signal levels

Rear panel connectors

- Mains connector, fused CEE connector for connection to a.c. mains supply
- Insertion connector, 5-pole female DIN connector for connection to ancillary equipment between the pre-amplifier and power amplifier stage
- Interconnect out connector, 5-pole female DIN connector for external connections to other PA equipment
- Interconnect in connector, 8-pole female DIN connector for external connections to other PA equipment
- Music out connector, 5-pole female DIN connector
- Call out connector, 5-pole female DIN connector
- Loudspeaker output connector, 12-pole female Trident Quickmate connector for high-level output to loudspeakers and spare input and error relay contacts
- d.c. power connector, 4-pole male Trident Quickmate connector for d.c. supply and remote d.c. on/off switching
- Chassis earth screw
- Cover for frame interconnection connector*

***Note:** The booster amplifiers are supplied with a blanking plate. A 15-pole D-type connector is used to connect a booster amplifier to a Module Extension Frame, or to another Booster Frame. The connector is supplied with the Frame Interconnection Module (FIM) and Power Supply Module (PSM).

Supplied with:

- Instructions for Use
- Installation Instructions
- Safety Instructions
- 12-pole male ITT Cannon Trident Quickmate connector
- 4-pole female ITT Cannon Trident Quickmate connector
- Connector ejector tool
- Cardboard cover
- System interconnection cable
- Mains cable (CEE type)

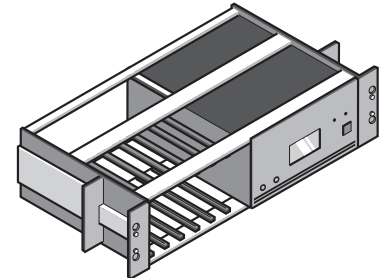
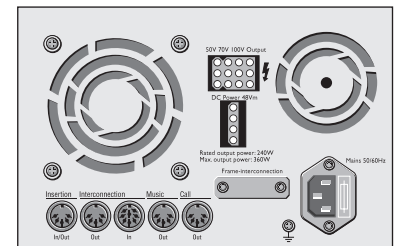
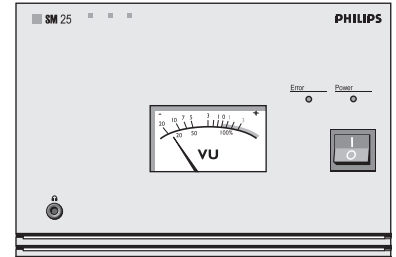

SM 25B SOUND MANAGEMENT

3. Boosters

60 + 120 W Dual Booster Frame LBB 2018/00 (F180D)

- 120 W call amplifier power and 60 W music amplifier power in one housing.
The total connected loudspeaker load may not exceed 120 W.
- Contains an SMPS power supply.
- Housing for up to six single-width SM 25B modules.

The 60 + 120 W Dual Booster Frame has the controls, indicators and connectors described on page 3.3, with the following differences.

Front panel controls and indicators

- Combined headphone output and VU meter monitoring selector switch

Rear panel connectors

- Insertion music connector, 5-pole female DIN connector for connection to ancillary equipment e.g. graphic equaliser between the pre-amplifier and power amplifier stage
- Insertion call connector, 5-pole female DIN connector for connection to ancillary equipment e.g. graphic equaliser between the pre-amplifier and power amplifier stage

These two connectors replace the single 5-pole insertion connector on the 60 W, 120 W and 240 W Booster Frames and Booster Amplifiers. In addition there are no Interconnect in and Interconnect out connectors.

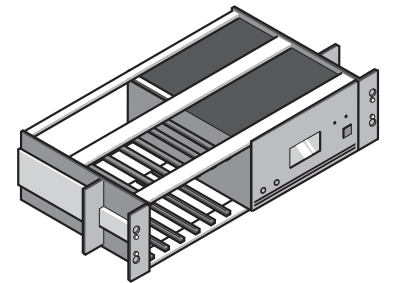
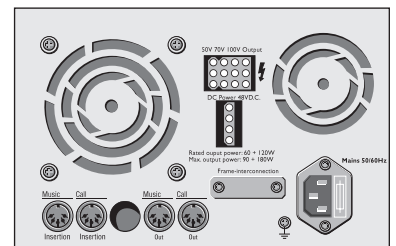
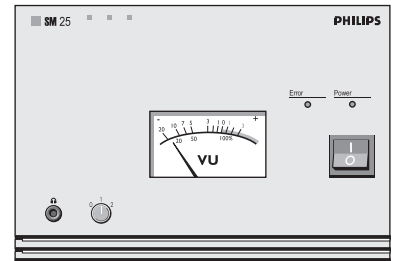

SM 25B SOUND MANAGEMENT

3. Boosters

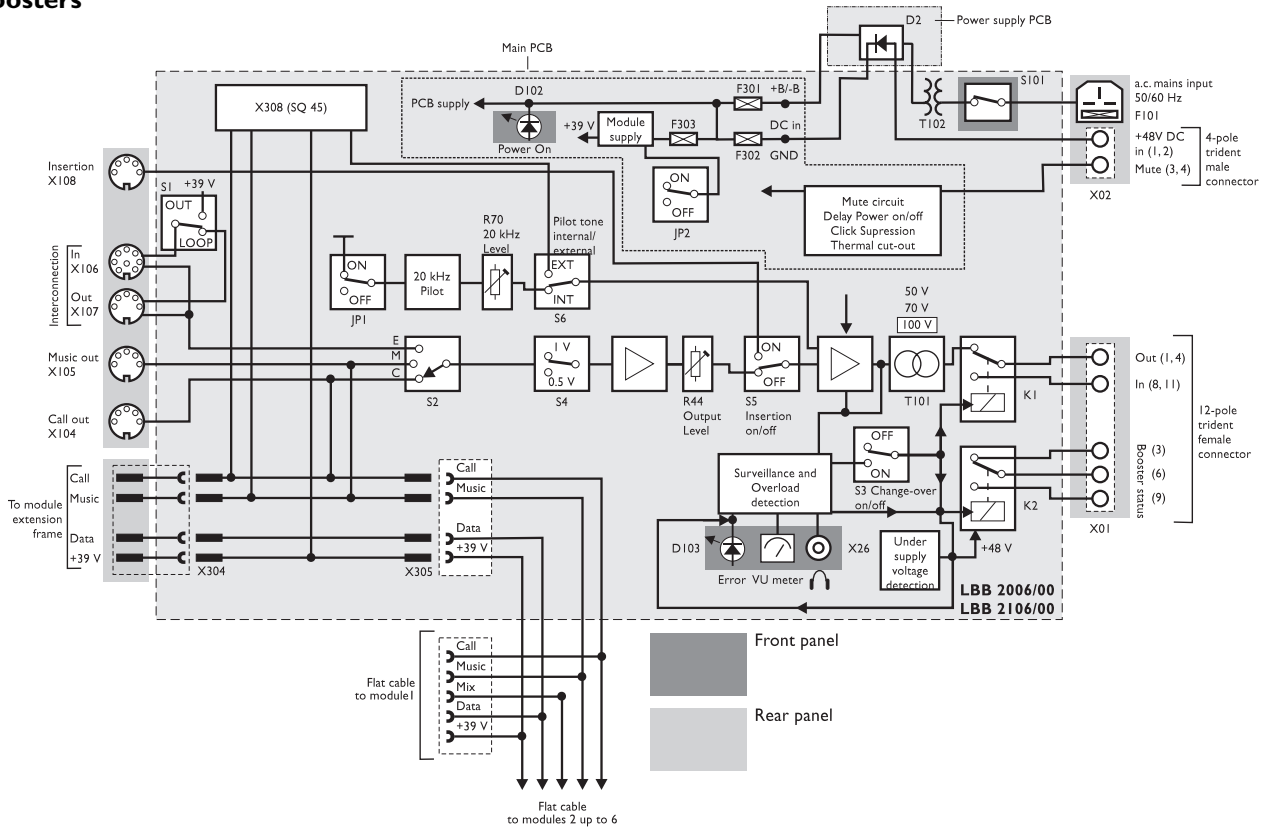

B60 and F60 Booster Frame block diagram

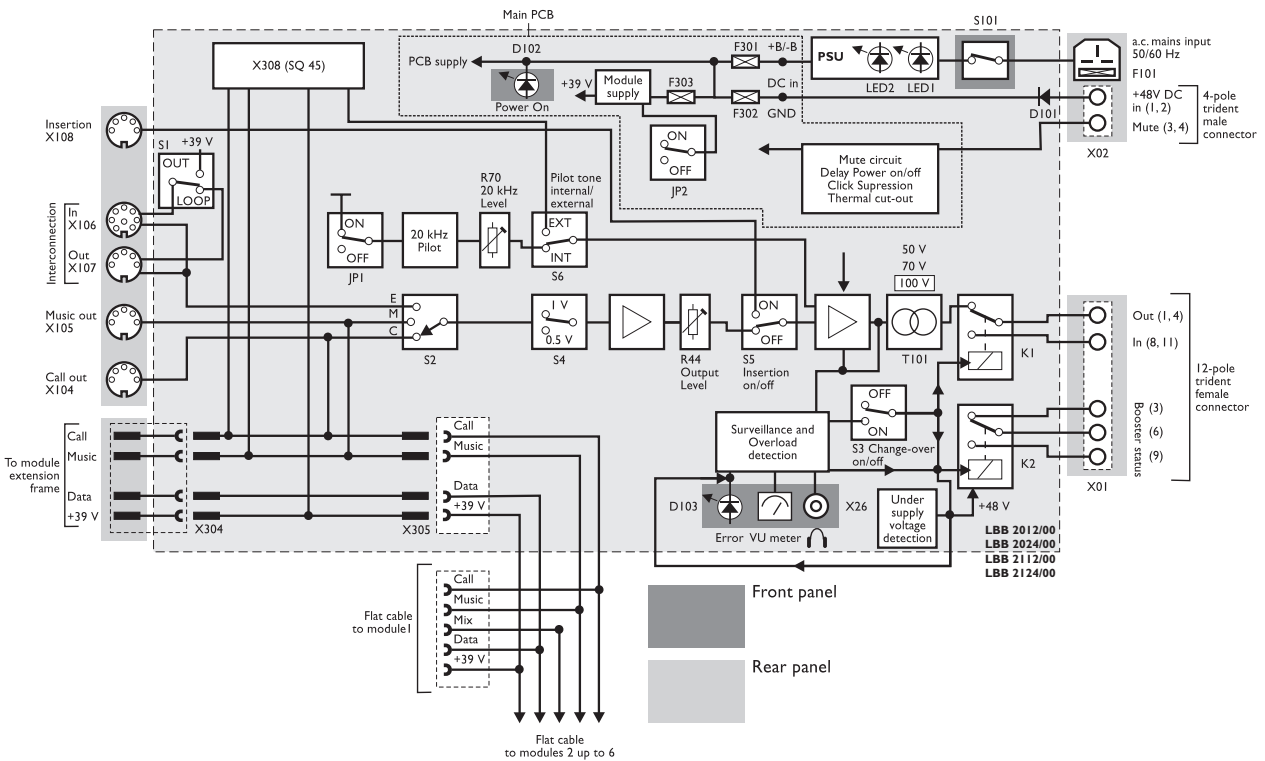

B120, B240, F120 and F240 Booster Frame block diagram

SM 25B SOUND MANAGEMENT

3. Boosters

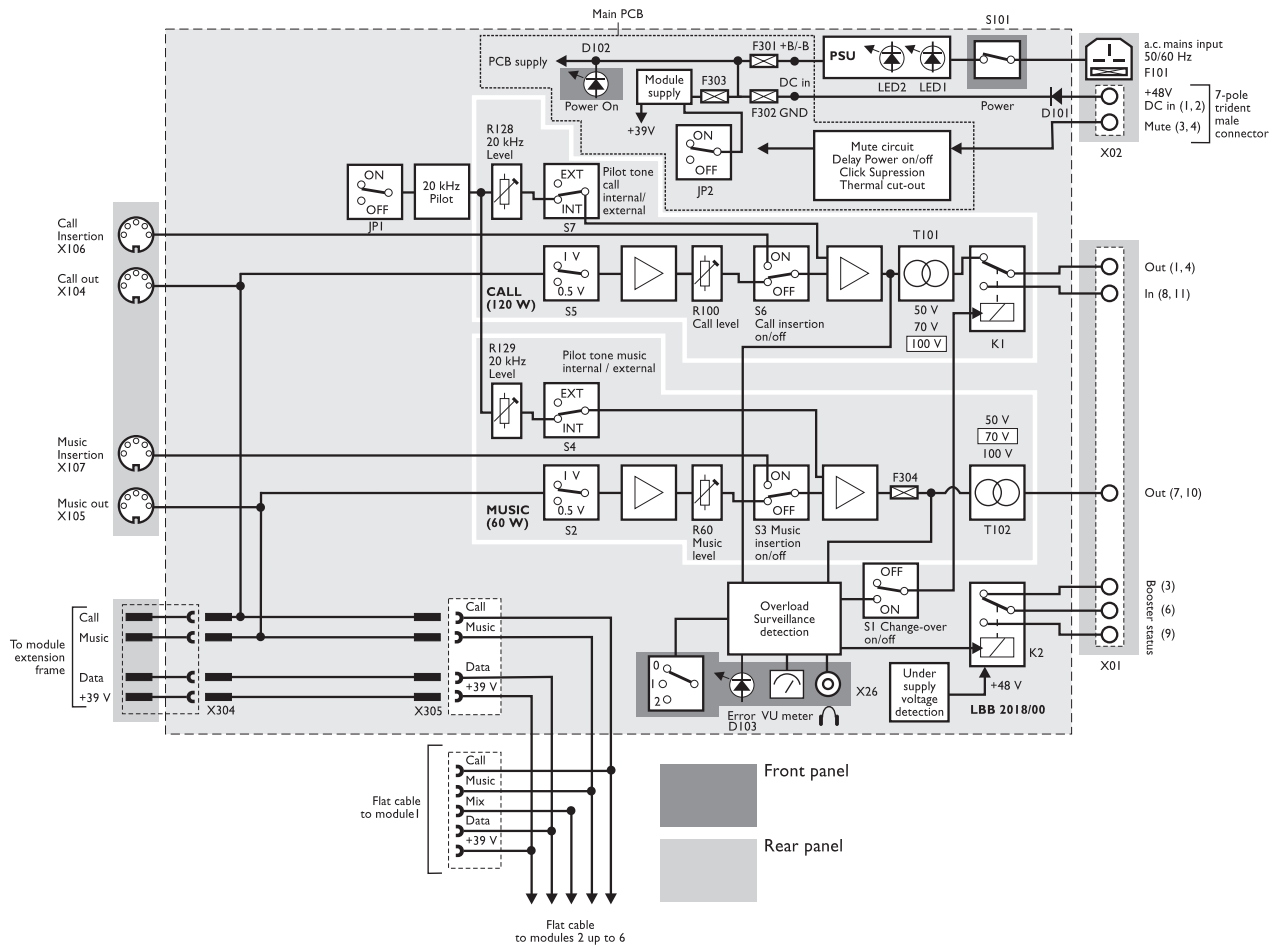

FI80D Booster Frame block diagram

SM 25B SOUND MANAGEMENT

3. Boosters

Technical data					
Booster amplifier output					
	B60/F60	B120/F120	F180D (call)	F180D (music)	B240/F240
rated output power	60 W	120 W	120 W	60 W	240 W
maximum output power	90 W	180 W	180 W	90 W	360 W
Rated output voltage	Rated load (Ω) / maximum capacitance (nF)				
50 V	41.5 / 120	20.7 / 240	20.7 / 240	41.5 / 120	10.4 / 480
70 V	83 / 60	41.5 / 120	41.5 / 120	83 / 60	20.7 / 240
100 V	166 / 30	83 / 60	83 / 60	166 / 30	41.5 / 120
Module system supply (on flat cable)					
System voltage	All types 39 Vd.c.				
Emergency supply					
Maximum voltage	58 Vd.c.				
Input signal levels					
Call, music, interconnection and insertion input					
Sensitivity	1 V \pm 20%				
Audio type	symmetrical balanced (insertion 1 V asymm)				
Input impedance	50 k Ω				
Maximum input voltage	8 Vrms				
Pilot tone input sensitivity	500 mV \pm 20%				
Pilot tone input impedance	100 k Ω				
Output signal levels					
Call and Music output					
voltage	1 V				
audio type	symmetrically balanced				
minimum load impedance	600 Ω				
Insertion output					
output voltage	1 V				
audio type	asymmetrical				
minimum load impedance	600 Ω				
Headphone					
unloaded output voltage	2.8 Vrms				
output impedance	68 Ω				
load impedance	8 to 600 Ω				
Output characteristics					
Distortion (THD)					
at 1 kHz	<1%				
at rated output power, -20 dB, at 10 kHz	<1%				
Frequency response					
at 10 dB below rated output power between 60 Hz and 20 kHz	+1 dB max / -3 dB min.				
Signal-to-noise ratio					
2 k Ω input, pilot tone off	> 80 dB (flat between 20 Hz and 20 kHz)				
Cross talk					
(F180D only)					
between inputs (at 1 kHz)	< -80 dB				
between inputs (at 10 kHz)	< -70 dB (reference to 1 V signal)				
Dimensions (in mm)					
H x W x D	F60 132 x 484 x 357	F120 132 x 484 x 357	F180D 132 x 484 x 357	F240 132 x 484 x 357	
Weight					
	13 kg	15 kg	16 kg	15 kg	
Dimensions (in mm)					
H x W x D	B60 132 x 202 x 355	B120 132 x 202 x 355	B240 132 x 202 x 355		
Weight					
	10 kg	12 kg	12 kg		

SM 25B SOUND MANAGEMENT

4. Power Supply Module

Type number	Description	Code	Page
LBB 2502/10	Power Supply Module	PSM	4.1

Introduction

The LBB 2502/10 is a Power Supply Module (PSM) for use in Module Extension Frames. It provides an additional power source for sound management systems that require more power than the Booster Frame (or Booster Amplifier) can supply. A PSM can supply an additional 35 PCF (0.7 A). For information about PCFs, refer to page 2.2. It is a dual-width module that occupies two module positions in a Module Extension Frame, and delivers power to the SM 25B via the system connector.

LBB 2502/10 (PSM)

- Provides power for modules in an SM 25B Module Extension Frame (MXF)
- Delivers an additional 35 PCF (0.7 A)
- 120 or 230 Va.c. mains operation
- 48 Vd.c. backup option
- Status relay contacts

Configurable functionality

The PSM is delivered for operation on 230 Va.c. mains. It can be configured for operation on 120 Va.c. or 240 Va.c. using 'Faston' connectors accessible when the PSM is withdrawn from the frame.

Controls and indicators

The following controls and indicators are located on the front panel:

- DC on indicator (yellow LED)
- Error indicator (red LED)
- Power indicator (green LED)
- Mains On/off switch

Interconnections

The following connectors are located on the rear panel:

- Mains input connector (fused CEE type plug)
- 15-pole mini D-type connector for system connection to other Booster Frames or Module Extension Frames via a Frame Interconnection Module (FIM) or Power Supply Module (PSM)
- DC power connector. This connector also has contacts for a status relay. This can be used for activating an alarm device in the event of a PSM failure. An internal system cable from the PSM powers modules in the MXF.

Supplied with:

- Instructions for use
- Installation instructions
- Safety instructions
- System interconnection cable with D-type connector
- Mains cord
- d.c. combination connector

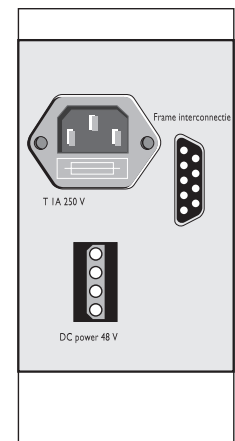
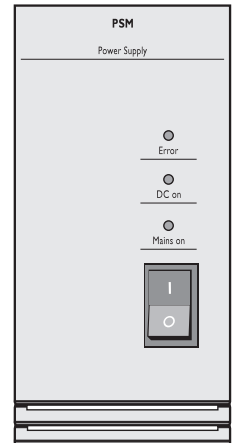

SM 25B SOUND MANAGEMENT

4. Power Supply Module

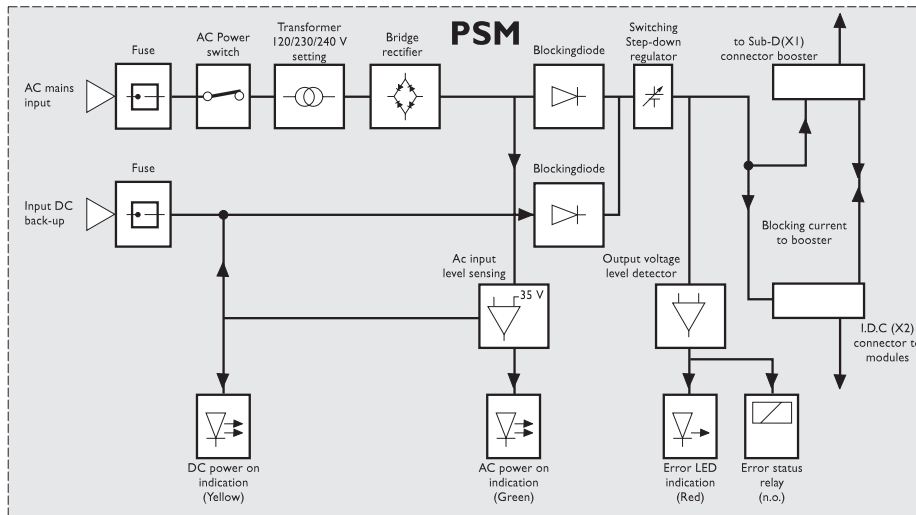

PSM block diagram

Technical data	
Mains voltage supply	120 (60 Hz), 230 and 240 Va.c. (50 Hz), selected by Faston settings Factory setting 230 V (50 Hz). 230/240 Va.c. -9% to +6%, 120 Va.c. -6% +10% Inrush current @ 230 V mains <10A
DC back up supply	44 to 58 V, Inrush current @ 48 V <4A (2 ms)
Supply output	Output voltage nominal value 39 ± 2 V Output current nominal value $0.7 \text{ A} \pm 5\%$ (35 pcf) Maximum output current limited (short circuit) to $2 \text{ A} \pm 10\%$ Output ripple over full input voltage range; $<200 \text{ mV}_{pp}$ (bandwidth 50 to 200 kHz) Output voltage regulation over input voltage range variation; $<0.1 \text{ V}$ output current constant Dynamic output resistance $<2 \text{ W}$ Turn on time $<50 \text{ ms}$
Power consumption	A.c. mains input; (120, 230 or 240 V) $5 \text{ VA} \pm 20\%$ @ output unloaded $45 \text{ VA} \pm 10\%$ @ output full loaded
D.c. back up input (48 V)	$25 \pm 5 \text{ mA}$ @ output unloaded $0.650 \text{ A} \pm 25 \text{ mA}$ @ output full loaded
Error indication	Error indicated by the red error LED on the front and closing of the PSM status relay when: <ul style="list-style-type: none"> Both input voltages are absent (only the status relay is closed) The output voltage is lower than 34 V
Error relay specification	<ul style="list-style-type: none"> Normally open (in normal working conditions and PSM switched on, the contact is open) 24 V d.c. 0.5 A, 100 Va.c. 0.5 A
Dimensions	67.3 x 132 x 230 mm
Weight	1.55 kg

SM 25B SOUND MANAGEMENT

5. Call Station Units

Type no.	Description	Code	Page
LBC 2500/10	Call Station Basic	CS-B	5.2
LBC 2502/10	Call Station Extension	CX-B	5.3

Introduction

SM 25B Call Station equipment consists of two dedicated units, the Call Station Basic and the Call Station Extension.

Call Stations

Up to nine Call Station units (Call Stations including Call Station Extensions) can be connected to a Call Station Module (CSM). A Call Station is for making calls, and can be assigned a priority level. Calls can be preceded by an optional two-tone or four-tone chime. A microphone on a flexible stem is provided. LEDs give status information. The Call Station's default setting routes calls to all loudspeaker zones connected. A Call Station may be configured using DIL switches to broadcast only to pre-selected zones.

Priority Status

Call Stations are assigned priority levels from 1 (lowest priority) to 5 (highest priority). When a Call Station with an assigned priority level is activated by pressing the PTT button on its top panel, all input signals with the lower priority level are muted. If more than one Call Station has the same priority level, the first Call Station to be activated will block all other Call Stations with the same priority level.

Call Station cables

The LBC 1520/10 cable is available in 100 m reels (see page 10.2) with four twisted pairs of 0.14 mm² cross-sectional area copper conductors. When this cable is used with a Call Station with 2 Call Station extensions and the cable length is longer than 750 m, it is advisable to connect the redundant fourth cable pair in parallel with the power.

The LBC 1510/10 cable is also available. It is a 10 m long cable terminated at both ends with 8-pole male DIN connectors (see page 10.2).

Call Station Extensions

One or two Call Station Extensions can be connected to a Call Station. Each unit allows calls to be sent to 12 different loudspeaker zones or groups of zones. A Call Station Extension has eight buttons, of which seven are user-programmable for any zone or zone group. The eighth button is an 'all-call' button, and is also used for programming the other seven. Zone selection is done via push-buttons.

Zone group selection

With two Zone Relay Modules installed in the Booster Frame, an SM 25B system may route calls to up to twelve loudspeaker zones. In combination with the Call Station, the Call Station Extension can be configured for extra functionality by re-programming buttons 1 through 7 to select a different combination of zones or groups of zones. Re-programming is easily done using the push-buttons on the top panel, and is achieved without having to open the CX-B or remove any system module.

SM 25B SOUND MANAGEMENT

5. Call Station Units

Call Station Basic

LBC 2500/10 (CS-B)

- Up to nine Call Stations or Call Station Extensions (CX-B) per Call Station Module
- Default all-call PTT button
- Choice of five priority levels
- Optional 2-tone or 4-tone chime to precede calls
- Designed for table-top use
- Integral microphone on a flexible stem
- For loop-through or branched configuration
- Up to 1 km from the Booster Frame
- A screened cable with at least three twisted-pairs is required to connect the CS-B to a CSM (a suitable available separately in 100 m reels or as pre-assembled 10 m long cables with connectors - see section 10)
- One or two Call Station Extensions can be connected to a Call Station

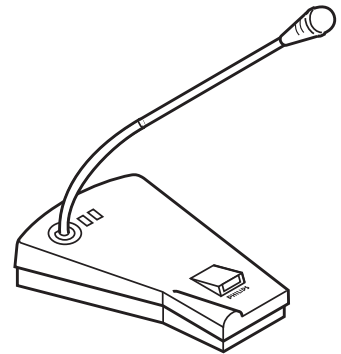

Configurable functionality

- Priority level 1 to 5, 5 is the highest (DIL switch)
- Two-tone or four-tone chime tone selection (DIL switch)
- Zone or zone group selection (DIL switch)
- Microphone input gain (jumper)
- System busy on demand (DIL switch)
- Speech filter on/off (jumper)

Controls and indicators - top panel

- On-air indicator (green LED) - Call Station is making a call
- System busy indicator (yellow LED) - another Call Station or microphone is making a call
- Press-to-talk (PTT) button, used when making a call

Rear panel connectors

- Two 8-pole female DIN connectors, for connecting the Call Station to the Call Station Module, or for loop-through connection to another Call Station

Supplied with:

- Instructions for use
- Installation instructions
- Safety Instructions
- Two 8-pole male DIN connector

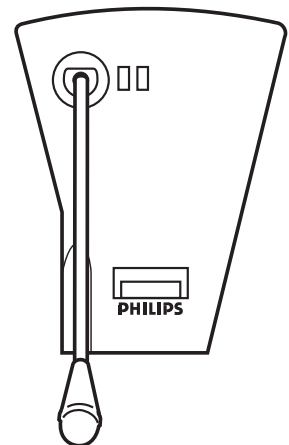

Technical data	
Inputs	
Nominal acoustical input level, 1 kHz	85 dB SPL \pm 3 dB
Peak acoustical input level	124 dB SPL \pm 3 dB
Equivalent acoustical input noise level	<33 dB SPL at nominal gain setting
Input sensitivity	-15 dB, 0 dB, +6 dB (jumper preset)
Outputs	
Nominal output level (At nominal acoustical input level and nominal (=0dB) gain setting)	0.7 V (-3 dBV \pm 1 dB)
Muted output level	-80 dB \pm 3 dB
Output impedance	
Symmetrical	<200 Ω
Load impedance symmetrical	>2 k Ω
Speech filter	
At 700 Hz	-3 dB \pm +1/-3 dB
Attenuation/octave	6 dB \pm 1 dB
Signal to noise ratio	>52 dB
Dimensions (in mm)	
H x W x D	90 x 160 x 200
Length of goose neck	380 mm
Weight	0.94 kg

SM 25 B SOUND MANAGEMENT

5. Call Station Units

Call Station Extension

LBB 2502/10 (CX-B)

- Programmable to select user-defined zone combinations
- Seven programmable buttons for loudspeaker zone selection
- Two Call Station Extensions can be connected to one Call Station
- The eighth button is an all-call button (not programmable)
- The CX-B is powered by the CSM via the CS-B
- Zone indicators next to buttons
- Identification labels provided

Default zone selection button programming

- buttons 1 to 6 selecting zones 1 to 6 (or zones 7 to 12 on a second CX-B)
- button 7 selecting zone group 1, 2 and 3 (or zones 7, 8 and 9 on a second CX-B)
- button 8 selecting all zones

Note: If two Call Station Extensions are connected, the one connected directly to the Call Station normally controls zones 1 to 6. However, it can be programmed to control other zones.

Controls and indicators:

The following controls and indicators are located on the top panel:

- Eight zone (or zone group) selection push buttons
- Eight zone (or zone group) selection indicators (yellow LEDs)

Interconnections:

The following connectors are located on the CX-B base

- Call Station system connector, 10-pole IDC flatcable, for connecting to the Call Station
- Call Station Extension system connector (10-pole IDC flatcable), for connecting to second Call Station Extension

Supplied with:

- Instructions for use
- Installation instructions
- Safety Instructions
- CS-B to CX-B connection cable
- CS-B to CX-B mounting bracket plus fixings
- Button identification labels

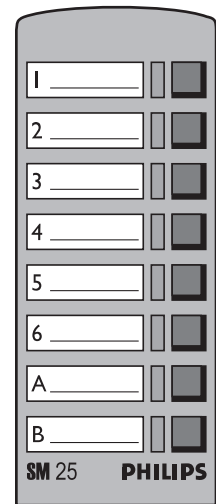
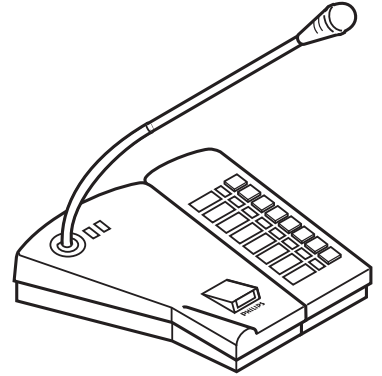

Technical Data	
Dimensions (in mm)	
H x W x D	70 x 95 x 200
Weight	0.27 kg

SM 25B SOUND MANAGEMENT

6. Input Modules

Type no.	Description	Code	Page
LBB 2520/10	General Mixing Module	GMM	6.2
LBB 2516/10	Mixing Input Module	MIX	6.3
LBB 2511/10	Call Station Module	CSM	6.6

Introduction

The SM 25B sound management system has three input modules: one for Call Station input (see section 5) and two for microphone/line inputs.

Mixing Input Modules

There are two mixing modules, the General Mixing Module (GMM) and the Mixing Input Module (MIX). Both modules are two-channel mixing input modules that incorporate user-selectable inputs for two microphones or two audio lines. The GMM also has one internal mix input (for internally mixed audio from Mixing Input Modules). Microphone inputs can be assigned with priority levels, and a chime tone can be set to precede announcements. The modules are powered from the Booster Frame.

Note: One GMM is always required per Booster Frame or Module Extension Frame.

Audio inputs

Each module has two inputs which can each be preset for use as either microphone inputs or line inputs. Built-in speech filters on both microphone input channels can be switched on to reduce the bass content of the input signal for improved speech intelligibility. A phantom power supply is available allowing condenser or dynamic microphones to be used. Audio sources such as cassette, FM tuner or CD player can be connected to line inputs. All connectors are located on the rear panel of the modules which, when mounted in a Booster Frame, are accessible from the rear of the Booster Frame.

Mixing modes

Two microphone mixing modes are available for each channel: one for microphones with remote switching contacts (mixing-on-demand), and one for microphones without remote contacts (mixing mode). If a microphone has no remote switching contacts, the mixing mode must be used (not mixing-on-demand). In both the mixing modes chimes are not available.

Priority inputs

For important announcements, the mode can be set to priority and microphones with remote switching contacts assigned priority levels from 1 (lowest priority) to 5 (highest priority). When a microphone with an assigned priority level is switched on, the channel input is activated and all signals below that priority level are muted. An optional chime with either two or four tones can be set to precede announcements on such channels. In case of priority, a limiter is activated both on microphone and line level inputs.

Dual-tone control adjustment

On the GMM, separate tone controls are provided for priority announcements (P1 to P5) and music, mixing or mixing-on-demand inputs. These can be preset to give the optimal setting for the selected audio source. Announcement and music tone controls are selected automatically according to how the inputs are configured.

SM 25B SOUND MANAGEMENT

6. Input Modules

General Mixing Module LBB 2510/20 (GMM)

- Two-channel mixing input module
- Choice of microphone or line inputs
- Selectable mixing modes for microphones with or without remote contacts
- Phantom power supply for microphones which require it
- Optional chime tones to precede announcements
- Built-in speech filter for improved speech intelligibility
- Dual tone controls for announcements and music
- Programmable zone selection per input

Controls and Indicators

The following controls and indicators are located on the front panel:

- Volume control - channel 1, for altering the volume of channel 1 audio output
- Volume control - channel 2, for altering the volume of channel 2 audio output
- Master volume control, for altering the overall volume of the GMM output
- Power indicator (green LED), indicates the presence of the module d.c. supply

Interconnections

The following connectors are located on the rear panel:

- Microphone input - channel 1, 5-pole female DIN, for audio announcements
- Microphone input - channel 2, 5-pole female DIN, for audio announcements
- Line input - channel 1, stereo cinch connector (internally wired for mono)
- Line input - channel 2, stereo cinch connector (internally wired for mono)

Configurable functionality

The following can be configured or adjusted:

- Up to five priority levels for each microphone input
- Mixing mode or mixing-on-demand mode
- 2-, 3- or 4-tone chimes to precede announcements
- Speech filters for spoken announcements
- Announcement and music tone controls
- Zone selection per input
- Single/dual channel selection for calls and music
- Inputs may be routed to music bus for background music
- Programmable zone selection for background music in single channel application

Supplied with:

- Instructions for use
- Installation Instructions
- Safety Instructions

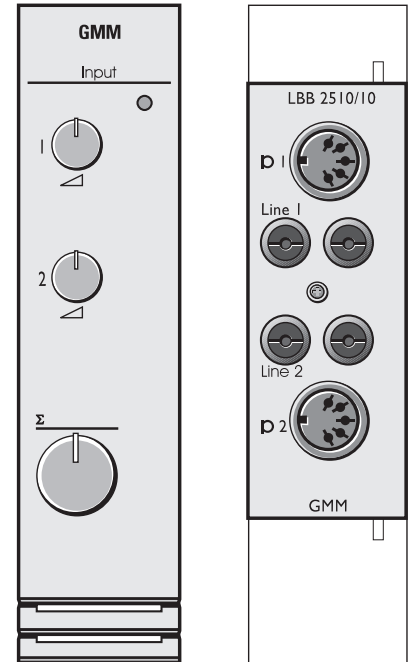

SM 25B SOUND MANAGEMENT

6. Input Modules

Mixing Input Module

LBB 2516/10 (MIX)

- Used in combination with GMM
- Two-channel mixing input module
- Choice of microphone or line inputs
- Selectable mixing modes for microphones with or without remote contacts
- For microphones with phantom power supply
- Optional chime tones to precede announcements
- Built-in speech filter for improved speech intelligibility
- Modular 'plug-and-play' design for quick and trouble-free installation

Controls and Indicators

The following controls and indicators are located on the front panel:

- Volume control - channel 1, for altering the volume of channel 1 audio output
- Volume control - channel 2, for altering the volume of channel 2 audio output
- Power indicator (green LED), indicates the presence of the module d.c. supply

Interconnections

The following connectors are located on the rear panel:

- Microphone input - channel 1, 5-pole female DIN, for audio announcements
- Microphone input - channel 2, 5-pole female DIN, for audio announcements
- Line input - channel 1, stereo cinch connector (internally wired for mono)
- Line input - channel 2, stereo cinch connector (internally wired for mono)

Configurable functionality

The following can be configured or adjusted:

- Up to five priority levels for each microphone input
- Mixing or mixing-on-demand mode
- Speech filters for spoken announcements
- 2-, 3- or 4-tone chimes to precede announcements

Supplied with:

- Instructions for use
- Installation Instructions
- Safety Instructions

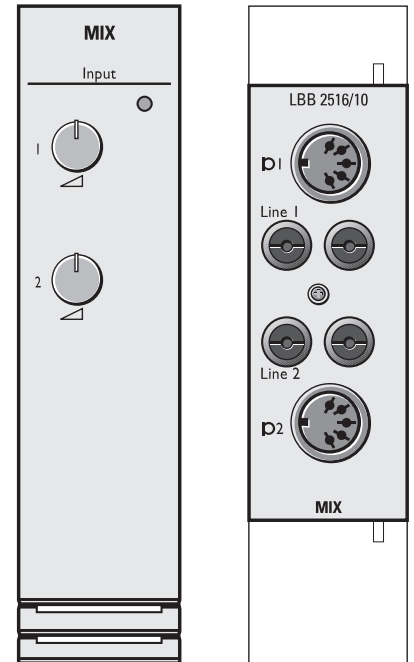

Technical data (GMM and MIX)	
Microphone inputs	
Input type	electronically balanced
Phantom supply	24 Vd.c.
Input sensitivity for 0 dBV output	0.5 mV ± 1 dB (min. level) 1.5 mV ± 1 dB (nom. level) 5.5 mV ± 1 dB (max. level)
Input impedance	8 kΩ
Line input	
Input type	unbalanced
Input sensitivity for 0 dBV output	210 mV (level mono) 110 mV (level stereo) 2V (maximum)
Input impedance	>10 kΩ
Filters	
Speech (switchable)	HPF, -3 dB at 315 Hz, 6 dB/oct
Announcement filter (GMM only)	
- low tone adjustable at 160 Hz -4 dB (± 2 dB) to +9 dB (± 2 dB)	
- high tone adjustable at 5 kHz 0 dB (± 1 dB) to +13 dB (± 2 dB)	
Music filter (GMM only)	
- low tone adjustable at 100 Hz -1 dB (± 1 dB) to +20 dB (± 2 dB)	
- high tone adjustable at 5 kHz -2 dB (± 1 dB) to +158 dB (± 2 dB)	
Dimensions	33.5 x 132 x 230 mm
Weight	0.24 kg (GMM), 0.22 kg (MIX)

SM 25B SOUND MANAGEMENT

6. Input Modules

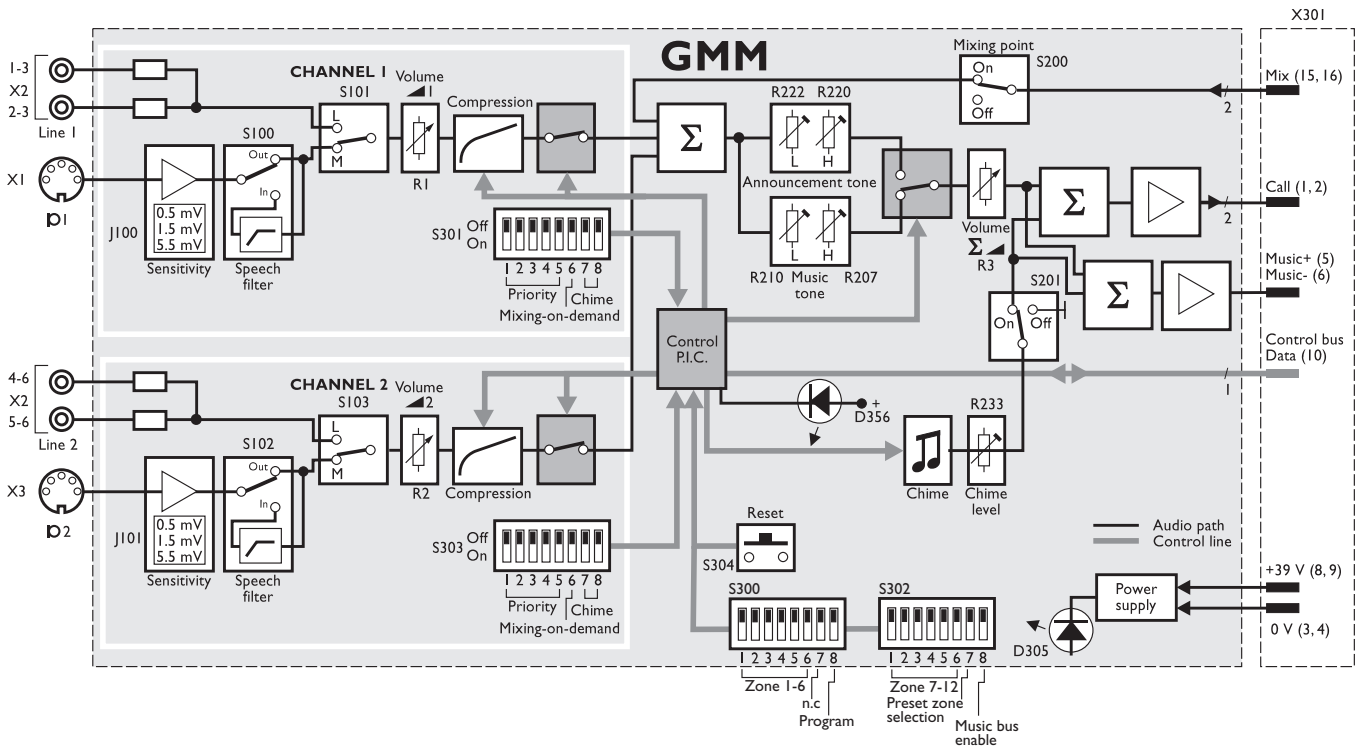

GMM block diagram

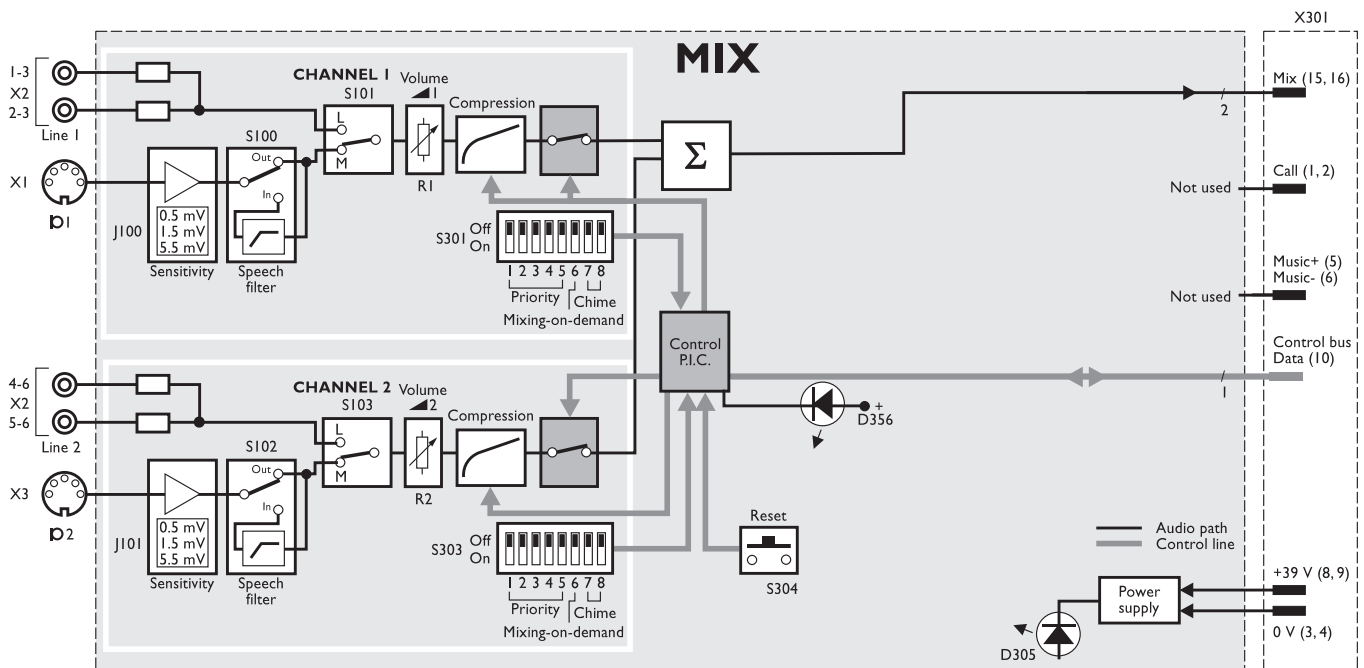

MIX block diagram

SM 25B SOUND MANAGEMENT

6. Input Modules

Call Station Module

The Call Station Module (CSM) connects Call Stations and a background music source to other modules in the SM 25B system. It is used in combination with the SM 25B Booster Frame, Call Station, Call Station Extension and Zone Relay Module to form a complete SM 25B sound management system. It can be configured so that background music is switched to the call line when no call is being made. The CSM's call and music outputs are routed to the Booster Amplifier inputs via the internal 16-pole system cable. The CSM is powered from the Booster Frame. To power Call Stations, the 39Vd.c. supply from the Booster Frame is also routed to the Call Station connectors.

Audio inputs

The CSM has two Call Station inputs and one auxiliary (music) line input. The two Call Station input sockets are internally wired in parallel and function identically. The auxiliary line inputs can be connected to music sources such as cassette, FM tuner or CD player. All sockets are located on the rear panel of the CSM, which when mounted in a Booster Frame, are accessible from the rear of the Booster Frame. A facility is also provided to mount a third connector.

SM 25B SOUND MANAGEMENT

6. Input Modules

Call Station Module

LBB 2511/10 (CSM)

- Call Station inputs and an auxiliary audio source input
- Dual tone control (for speech and music)
- Volume control for music input
- Modular 'plug-and-play' design for quick and trouble-free installation

Controls and Indicators

The following controls and indicators are located on the front panel:

- Power indicator (green LED), indicates the presence of the module d.c. supply
- Volume control, controls the level of the music input (if present)

Interconnections

The following connectors are located on the rear panel:

- Two call station inputs, 8-pole female 270° DIN, for connecting to Call Stations
- A third position for an additional 8-pole female DIN is provided, but no connector is fitted on the module's printed circuit board
- Auxiliary input, stereo cinch (internally wired for mono), for connecting an auxiliary music source

Configurable functionality

On the CSM the following can be configured:

- Background music on call line
- Call Station input gain
- Chime level
- Adjustment of high and low call tone (Call Station input)
- Adjustment of high and low tone for background music (line input)

Supplied with:

- Instructions for use
- Installation instructions
- Safety instructions
- Two 8-pole DIN connectors

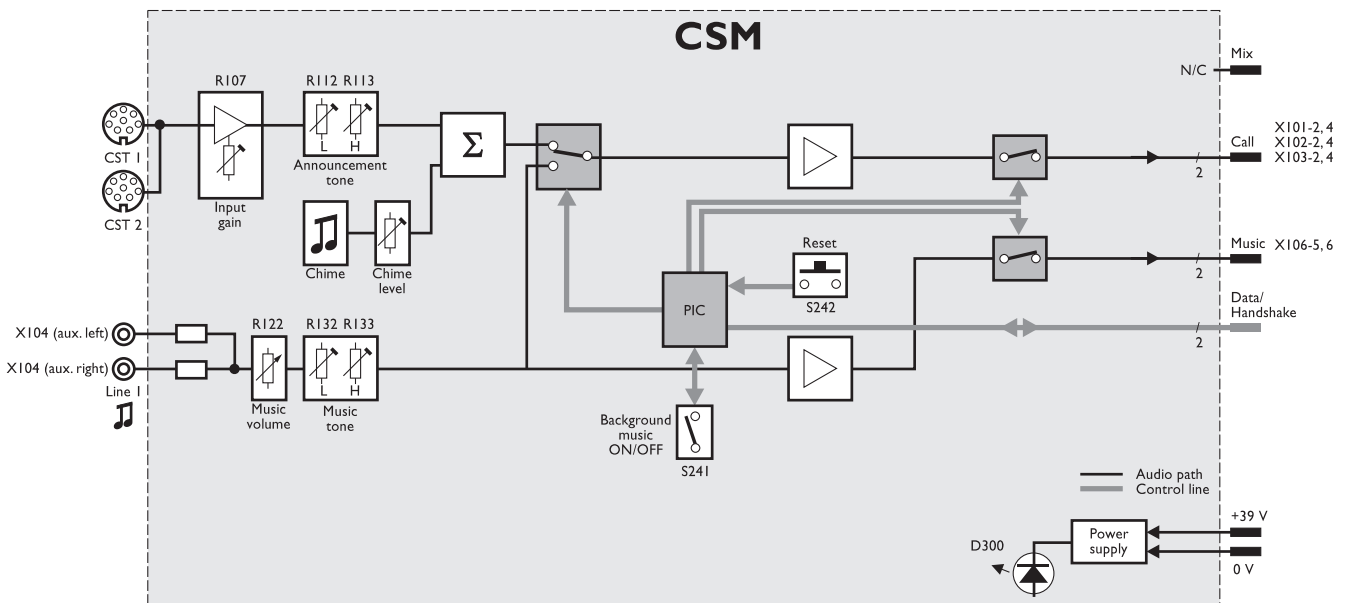
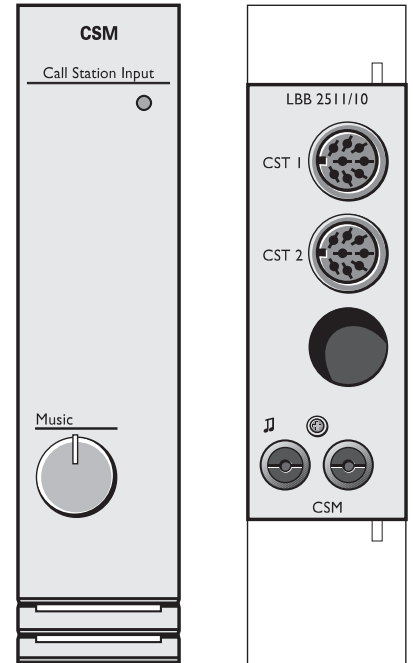

SM 25B SOUND MANAGEMENT

6. Input Modules

Technical data	
Inputs	
Call Station inputs	
Call audio input level nominal for 0 dBV output	+6 dBV ± 1 dB symmetrical
Auxiliary inputs	
Auxiliary input level	0.2 to 2 VRMS
Outputs	
Cross talk	
From CS-B audio input to music output (gain preset maximum)	>70 dB (at 1 kHz) >63 dB (at 10 kHz)
From aux. input to call output (gain preset maximum)	>77 dB (at 1 kHz) >70 dB (at 10 kHz)
Announcement filter	
Low tone adjustable at 160 Hz	-4 dB (± 2 dB) to +9 dB (± 3 dB)
High tone adjustable at 5 kHz	0 dB (± 2 dB) to +13 (± 3 dB)
Music filter	
Low tone adjustable at 100 Hz	0 dB (± 2 dB) to +20 dB (± 3 dB)
High tone adjustable at 15 kHz	0 dB (± 2 dB) to +18 dB (± 3 dB)
Environmental requirements	
Ambient temperature	0 to +55 °C
Relative humidity	15 to 90%
Quality and serviceability requirements	
M.T.B.F.	50,000 hours at 55 °C
M.T.T.R.	< 30 minutes
Dimensions	33.5 x 132 x 230 mm
Weight	0.20 kg

SM 25B SOUND MANAGEMENT

7. Sound modules

Type no.	Description	Code	Page
LBB 2521/10	Tuner Module	TUM	7.6
LBB 2540/10	Alarm Routing Module	ARM	7.2
LBB 2541/10	Recordable Message Module	RMM	7.4

Introduction

Alarm Routing Module

The LBB 2540/10 is an Alarm Routing Module (ARM) for use in Booster Frames and Module Extension Frames. It has a separate external alarm and a time signal triggering input. Each ARM can generate one alarm and one time signal, activated by input one and input two respectively. Either the alarm or the time signal can be set to all-call. This leaves the other signal available for pre-selected zones. If different signals or different zone routing is required in the same SM 25B system, additional ARMs can be added to the system. The alarm or time signal can be programmed for a particular zone or group of zones, and can be assigned a priority level (1 to 5). It is a single-width module that occupies one module position in a frame. It is powered via the SM 25B system connector.

Recordable Message Module

The LBB 2541/10 is a Recordable Message Module (RMM) for use in Booster Frames and Module Extension Frames. It is a digital recorder for recording, monitoring and playing back up to 10 messages with a total playing time of 132 seconds. Up to three additional memory modules can be added to the RMM printed circuit board to increase the total playing time to 528 seconds. Messages are backed up using NiCd batteries. Messages are recorded using the GMM/MIX module or CS-B via the SM 25B system bus. Messages can be remotely activated via the input/output connector on the rear panel.

Tuner Module

The LBB 2521/10 is an FM Tuner Module (TUM) for use in Booster Frames and Module Extension Frames. It provides a convenient background music source (mono) for call systems fitted with a LBB 2511/10 Call Station Module (CSM). It is a dual-width module that occupies two module positions in a frame, and is powered via the SM 25B system connector.

SM 25B SOUND MANAGEMENT

7. Sound modules

LBB 2540/10 (ARM)

- Alarm and time signal generator
- Generates one of 15 alarm signals
- Generates one of 7 time signals
- Selection of five priority levels
- Routes alarm or time signals to pre-defined zones, or all call (routing to all zones)
- Separate external alarm and time signal triggering
- Selectable signal activation and deactivation properties
- Modular 'plug-and-play' design for quick and trouble-free installation

Controls and indicators

The following indicator is located on the front panel:

- Power indicator (green LED), indicates the presence of the module d.c. supply
- Optional external LEDs can be connected in series with the alarm or time signal switches

No other indicators or controls are required.

Interconnections

The following connectors are located on the rear panel:

- Alarm signal trigger input, 5-pole female DIN, to trigger alarm signals
- Time signal trigger input, 5-pole female DIN, to trigger time signals

Configurable functionality

On the ARM, the following can be configured or adjusted:

- Priority level 1 to 5 (alarm signal input)
- Priority level 1 to 5 (time signal input)
- Alarm/time signal routing (all call or zone selection)
- Alarm or time signal zone selection (zones 1 to 12)
- Alarm signal (15 signals available)
- Alarm signal activation/deactivation properties
- Time signal (7 signals available)
- Time signal activation/deactivation properties
- Alarm and time signal level

Supplied with:

- Installation Instructions
- Safety instructions

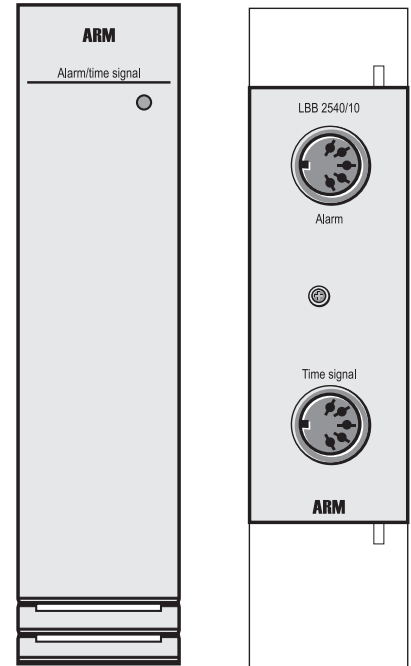

Technical data		
Module functions		
Time signal selection	1.2 kHz for 1 s 440 Hz for 4 s 554 Hz for 4 s 1 kHz for 4 s	2-tone chime 554 Hz (0.8s), 440 Hz (2s) 3-tone chime 392 Hz (0.8s), 523 Hz (0.8s), 659 Hz (1.6s) repeating twice 4-tone chime 554 Hz (0.8s), 440 Hz (0.8s), 493 Hz (0.8s) 330 Hz (2s)
Alarm signal selection	Slow Whoop 60 s; 500 to 1200 Hz sweep (in 1 s, pause 1 s) Slow Whoop key-release; 500 to 1200 Hz sweep (in 1 s, pause 1 s) DIN Alarm 60 s; 1200 to 500 Hz sweep (1 s repeating) DIN Alarm key-release; 1200 to 500 Hz sweep (1 s repeating) Evacuation key-release; 554 Hz (100 ms), 440 Hz (400 ms) Immediate danger key-release; 600 Hz (200 ms), pause (200 ms) Fire alarm 60 s; 440 Hz (12 s on, 12 s off) Slow Whoop key-release; 500 to 1200 Hz (in 3.5 s, pause 0.5 s) Two-tone alarm 60 s; 440 Hz (1 s), 554 Hz (1 s) Base tone key-release; 440 Hz continuous Pulse alarm 60 s; 1000 Hz (300 ms), pause (200 ms) Morse A (di-dah), repeating, 1200 Hz signal, 12 WPM Morse F (di-di-dah-dit), repeating, 1200 Hz signal, 12 WPM Morse A (di-dah), repeating 120s unless stopped by key, 400 Hz, 12WPM Morse A (di-dah), repeating, 440 Hz, 12WPM	
Dimensions	33.5 x 132 x 230 mm	
Weight	0.24 kg	

SM 25B SOUND MANAGEMENT

7. Sound modules

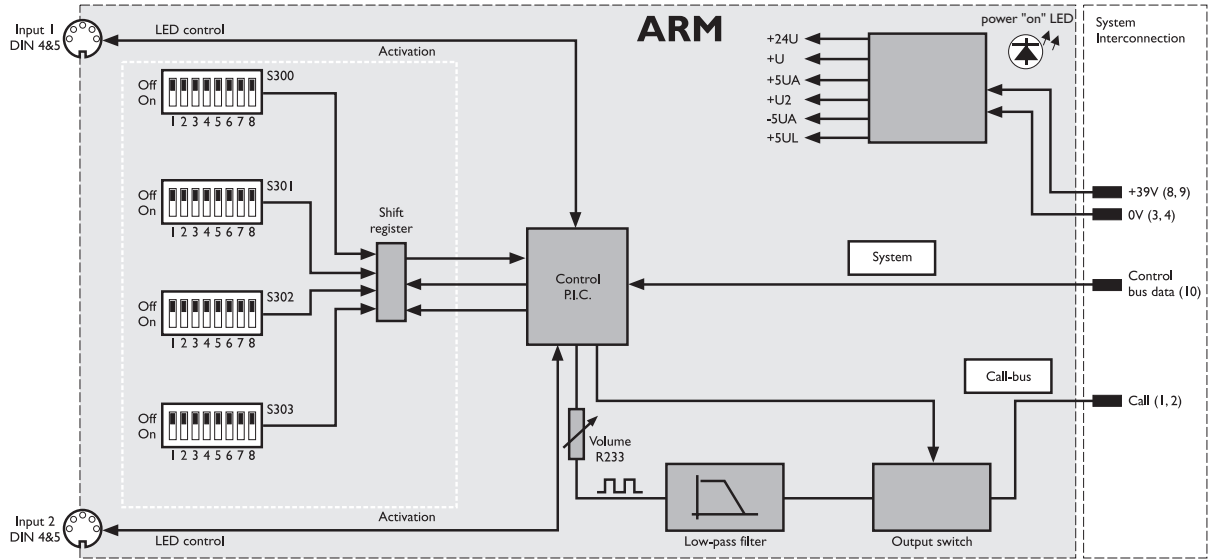

ARM block diagram

SM 25B SOUND MANAGEMENT

7. Sound modules

LBB 2541/10 (RMM)

- Digital recorder for recording, monitoring and playing back messages
- Maximum of 10 messages
- Up to 132 seconds of recording time
- Recording time can be expanded to up to 528 seconds
- Messages are recorded via the SM 25B system bus, using the CSM or GMM/MIX modules
- Selection of five priority levels for each message
- Routes each message to pre-defined zones, or all call (messages routed to all zones)
- Remote message triggering
- Selectable message activation and deactivation properties
- Battery backup using NiCd batteries
- External indication relay function
- Modular 'plug-and-play' design for quick and trouble-free installation

Controls and indicators

The following controls and indicators are located on the front panel:

- Power indicator (green LED), indicates the presence of the module d.c. supply
- Play indicator (green LED), indicates that the module is in play mode
- Record indicator (red LED), indicates that the module is in record mode
- Monitor indicator (yellow LED), indicates that the module is in monitor mode
- Pre-selected message indicator (7-segment display), indicates the selected message
- Mode selector (inset toggle push button), selects between the three modes
- Start/stop push button, activates/deactivates functions depending on the selected mode
- Message select push button, selects pre-recorded messages
- 3.5 mm stereo headphone jack (internally wired for mono), for connecting headphones to monitor messages

Interconnections

The following connector is located on the rear panel:

- 15-way input/output connector, for play request and message run relay

Configurable functionality

On the RMM, the following can be configured or adjusted:

- Priority level 1 to 5 for each message recorded
- Zone selection for each message recorded (any combination of 12 zones)
- External indication of message playing for each message input
- Message activation/deactivation properties for each individual message input
- Separate audio output level and headphone volume level adjustments

Supplied with:

- Installation and User Instructions
- Safety instructions

Technical data				
Module functions				
Maximum no. of messages	10			
No. of memory modules	1	2	3	4
Maximum playback time	2 m:12 s	4 m:24 s	6 m:36 s	8 m:48 s
Backup time (new batteries)	80 days	60 days	40 days	20 days
Backup time (batteries approx. 5 years old)	40 days	30 days	20 days	10 days
SM 25B power consumption factor (PCF)	3.5			
Remote play request connector	CMOS level 5V, internal pull-up			
Message active relay contacts	30 V, 0.5 A max.			
Output characteristics				
Audio bandwidth	40 to 5,000 Hz (-6 dB, complete record and playback cycle)			
THDN	<3%			
Dynamic range	>55 dB			
Headphone output	2.8 V max.			
Dimensions	33.5 x 132 x 230 mm			
Weight	0.32 kg			

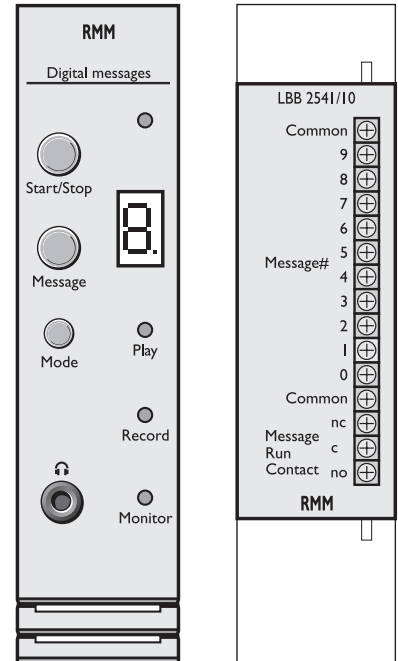

SM 25B SOUND MANAGEMENT

7. Sound modules

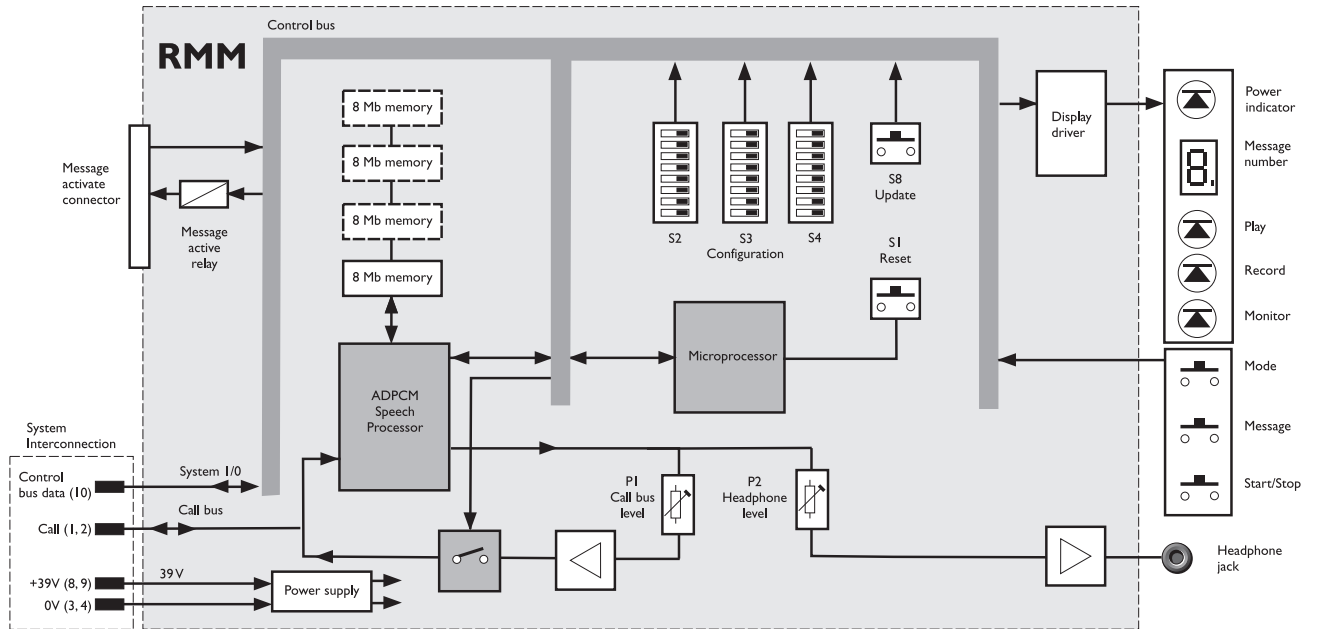

RMM block diagram

SM 25B SOUND MANAGEMENT

7. Sound modules

Tuner Module LBB 2521/10 (TUM)

- Music source for SM 25B modular sound management
- FM tuner with 87.5 to 108 MHz tuning range
- Four pre-set stations plus 'off' position
- Pre-set volume control
- Calibrated frequency meter

Configurable functionality

On the TUM, the following can be configured:

- Volume can be preset during installation using a volume control on the printed circuit board.
- The automatic frequency control (AFC) can be switched on and off.

Controls and indicators

The following controls and indicators are located on the front panel:

- Individual rotary controls enable four stations to be preset.
- A five position switch (4 stations plus off) for selecting stations.
- A tuning meter displaying the full FM tuning range (88 to 108 MHz).
- Power indicator

Interconnections

The following connectors are located on the rear panel:

- Aerial (antenna) connection
- Audio output. Audio from the TUM is fed to the SM 25B music bus via the auxiliary input of the CSM.

Supplied with:

- Instructions for use
- Installation instructions
- Safety instructions
- Cinch cable

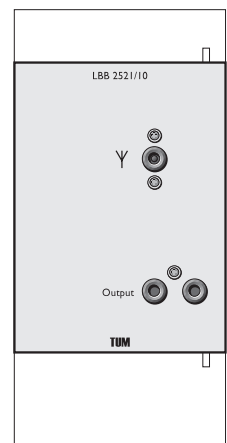
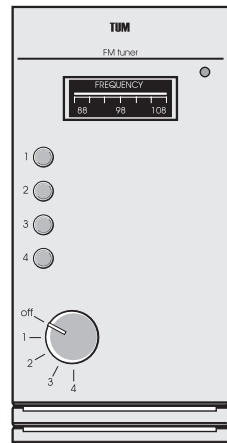

Technical data	
Interference suppression acc. to ZZF, EN55013 (emission) and EN55020 (immunity)	
Frequency range	87.5 Hz to 108 MHz
Frequency response	40 Hz to 12 kHz
Sensitivity	<2µV for 26 dB S/N, 75 kHz deviation
Alternate channel selectivity (± 300 kHz)	> 60 dB
Distortion at 40 kHz Deviation and f=1 kHz	< 1%
Signal-to-noise ratio at 40 kHz deviation	≥ 55 dB
AM suppression	≥ 40 dB
Pilot frequency suppression	≥ 35 dB
Aerial impedance	75 Ω
Dimensions	67.3 x 132.5 x 233 mm
Weight	0.43 kg

SM 25B SOUND MANAGEMENT

7. Sound modules

FM tuner part	
Frequency range	FM 87.5 Hz to 108 MHz, tolerances -300 +500 kHz
Signal strength FM	60 dB (mV)/75 Ω
Tolerance including trimming, AFC, Drift = F(t) acc. DIN, IEC 315-1, drift = F(V)	acc. DIN, IEC 315-1
Notes:	
A.AFC: only 'pull in range', readjusted until reference output has been reached	
B. FM-RF realignment procedure must be indicated in the documentation	
Intermediate frequency	FM 10.7 MHz, tolerances ± 500 kHz
Generation of interference	EN55013

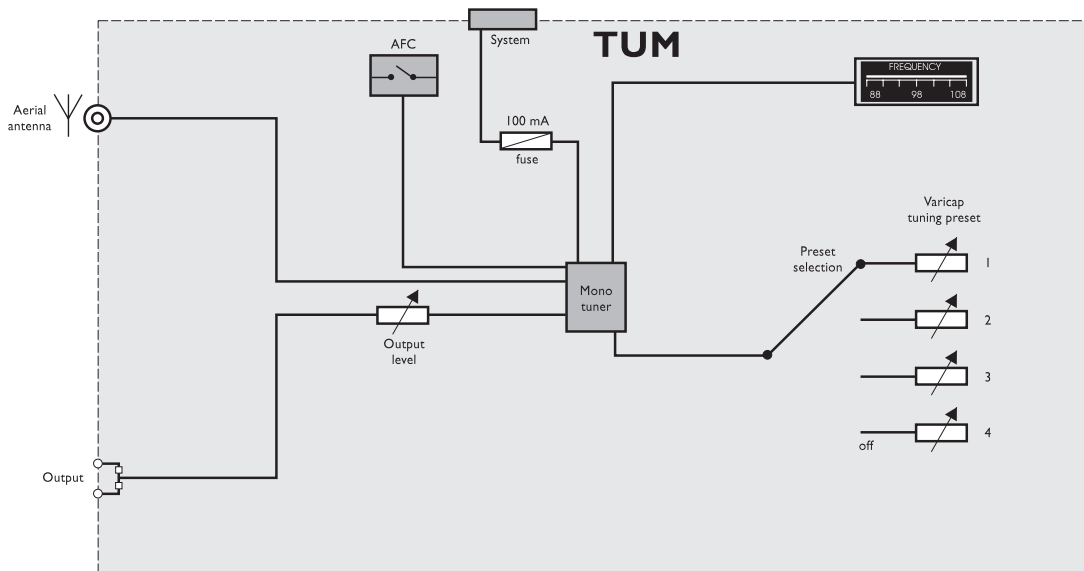

TUM block diagram

SM 25B SOUND MANAGEMENT

8. Output Modules

Type no.	Description	Code	Page
LBB 2550/00	Manual Zone Switch Module	MZS	8.3
LBB 2551/10	Zone Relay Module	ZRM	8.2

Introduction

The SM 25B sound management system has two types of output modules: one for automatic zone selection and one for manual zone selection. These modules receive outputs from the Booster Frame amplifier(s), and route high-voltage (100, 70 or 50 V) outputs to the system loudspeaker zones.

Automatic zone selection

The Booster Amplifier's audio outputs (call and music) can be automatically routed to loudspeaker zones using the ZRM. A maximum of two ZRMs (12 zones) may be used in an SM 25B system. Depending on the zone-relays activated (by a Call Station or Call Station Extension), audio inputs are switched through to the appropriate loudspeaker zones.

The ZRM can be configured with zones short-circuited to prevent cross talk between 100 V loudspeaker lines. When no call signal is present on a loudspeaker zone, the ZRM can be configured to automatically route background music or a 20 kHz pilot tone to that zone.

Manual zone selection

The Booster Amplifier's audio outputs can be manually routed to zones using the MZS. Any number of MZS may be used in an SM 25B system. Depending on the zone-buttons selected, audio signals are switched through to the appropriate loudspeaker zones.

The MZS can be configured with zones short-circuited to prevent cross talk between 100 V loudspeaker lines. When no call signal is present on a loudspeaker zone, the MZS can be configured to automatically route background music or a 20 kHz pilot tone to that zone.

SM 25B SOUND MANAGEMENT

8. Output Modules

Zone Relay Module

LBB 2551/10 (ZRM)

- Automatic selection of up to six loudspeaker zones
- Works with CSM and CS-B/CX-B, and GMM/MIX
- Music or pilot tone may be broadcast to call-standby zones
- Separate call amplifier input for zones 5 and 6
- Two 12-pole ITT Cannon Trident Quickmate connectors
- Twelve separate loudspeaker zones with two ZRMs
- Additional ZRMs can be connected in parallel

Controls and indicators

The following indicator is located on the front panel:

- Power indicator (green LED), indicates the presence of the module d.c. supply

Interconnections

The following connectors are located on the rear panel:

- Amplifier in connector, 12-pole male ITT Cannon Trident Quickmate connector for connecting audio input from the Booster Frame amplifier(s)
- Amplifier out connector, 12-pole female ITT Cannon Trident Quickmate connector for connecting high-level audio output to the loudspeakers

Configurable functionality

On the ZRM, the following can be configured:

- Signal broadcast in standby mode of each zone can be individually configured to select which signal (background music, pilot tone or none) is broadcast to the loudspeaker zones that are in standby mode, i.e. when no call is being made on that zone.
- Zones 1-6 or 7-12
- Separate call input for zones 5 and 6 (or zones 11 and 12 in a 12-zone configuration)

Supplied with:

- Installation Instructions
- Safety Instructions
- 12-pole male ITT Cannon Trident Quickmate mating connector
- 12-pole female ITT Cannon Trident Quickmate mating connector
- Connector ejector tool

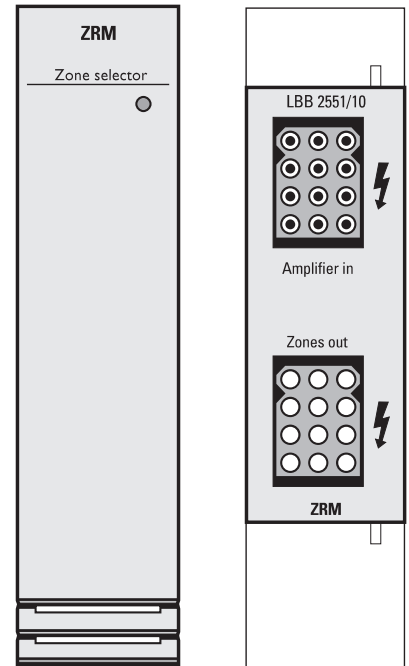

Technical data ZRM	
Inputs	
maximum voltage	110 Va.c. RMS audio continuous
maximum current	4 Aa.c. RMS audio continuous
Outputs	
maximum voltage	110 Va.c. RMS audio continuous
maximum current	4 Aa.c. RMS audio continuous
Specification of the relays	
Operating temperature	0 to +55 °C
Contact material	no Cadmium Oxide
Nominal load contacts	4A 110Va.c.
System supply voltage	+39Vd.c. ± 2V
Maximum supply current	110 mAd.c.
Nominal supply current (standby position)	41 mAd.c.
Nominal supply current (call position)	12 mAd.c.
Dimensions	33.5 x 132 x 230 mm
Weight	0.43 kg

SM 25B SOUND MANAGEMENT

8. Output Modules

Manual Zone Switch Module

LBB 2550/00 (MZS)

- Manual push-button selection of up to six loudspeaker zones
- Music or pilot tone may be broadcast to call-standby zones
- Two 12-pole ITT Cannon Trident Quickmate connectors
- Modular 'plug-and-play' design for quick and trouble-free installation
- Several MZS modules may be mounted in a Booster Frame
- Numerous loudspeaker zones can be serviced
- No power supply required.

Configurable functionality

On the MZS, the following can be configured:

- Background music or pilot tone can be sent individually to each zone when no call is being made to the zone. Alternatively, zones can be short circuited when no call is being made.

Controls and Indicators

The following controls are located on the front panel:

- Six zone selection push buttons for routing audio output to loudspeaker zones

Interconnections

The following connectors are located on the rear panel:

- Amplifier in connector, 12-pole male Trident Quickmate connector for connecting audio input from the Booster Frame amplifier
- Amplifier out connector, 12-pole female Trident Quickmate connector for connecting high-level audio output to the loudspeakers

Supplied with:

- Instructions for use
- Installation Instructions
- Safety Instructions
- 12-pole male ITT Cannon Trident Quickmate mating connector
- 12-pole female ITT Cannon Trident Quickmate mating connector
- Connector ejector tool
- Application note
- MZS to ZRM interconnection cable, enabling manual zone selection for music

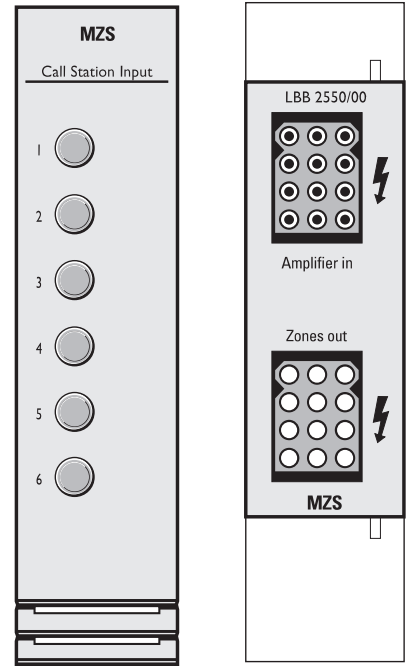

Technical data MZS	
Inputs	
maximum voltage	100 Va.c. audio continuous
maximum current	4 Aa.c. audio continuous
Outputs	
maximum voltage	100 Va.c. audio continuous
maximum current	4 Aa.c. audio continuous
Dimensions	33.5 x 132 x 230 mm
Weight	0.36 kg

SM 25B SOUND MANAGEMENT

8. Output Modules

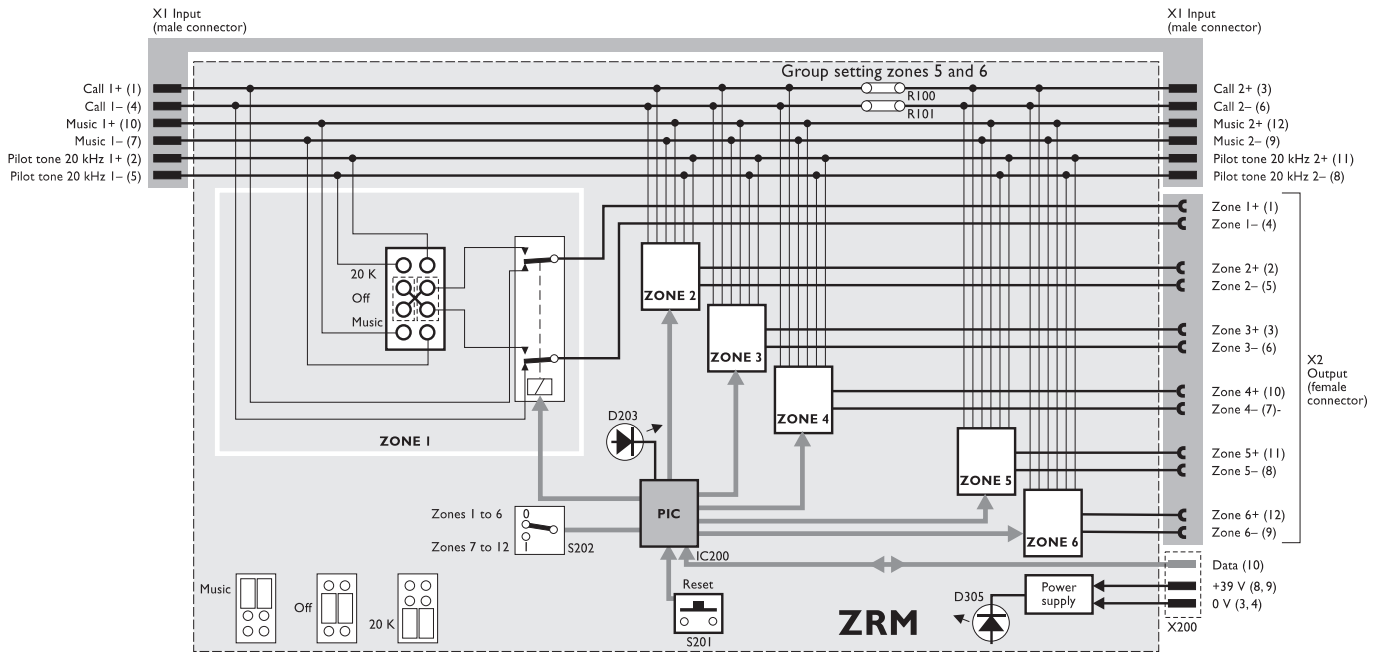

ZRM block diagram

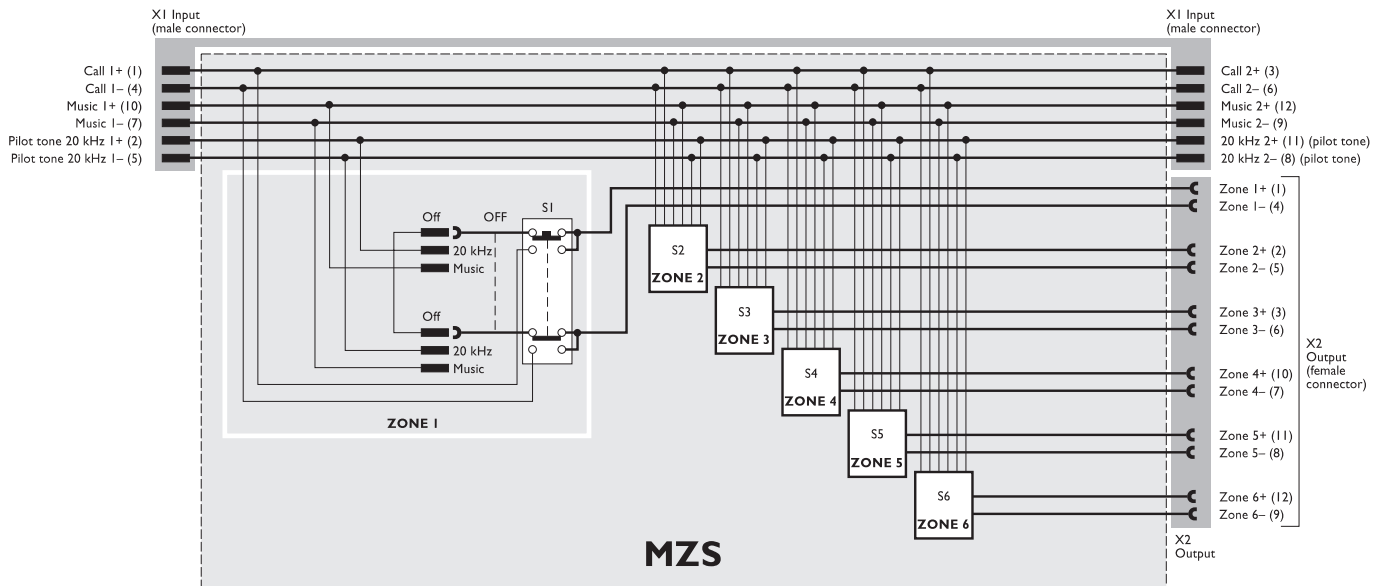

MZS block diagram

SM 25B SOUND MANAGEMENT

9. Ancillary equipment

Type no.	Description	Code
LBB 2500/00	Module Extension Frame MXF	
LBB 2505/10	Frame Interconnection Module	FIM
LBB 2503/00	Booster Connection Board BCB	

Ancillary equipment

A range of ancillary equipment is available to add to and complement the SM 25B sound management system.

Module Extension Frame

LBB 2500/00 (MXF)

- Provides additional housing for up to eleven additional SM 25B modules
- Requires a FIM (takes one position in the MXF) or PSM (takes two positions in the MXF)
- Easily attached to a 19-inch rack
- Modules in the Module Extension Frame can be powered from the Booster Frame
- Dimensions in mm (H x W x D): 132 x 484 x 230
- Weight: 5 kg

Supplied with:

- Installation instructions
- Safety instructions

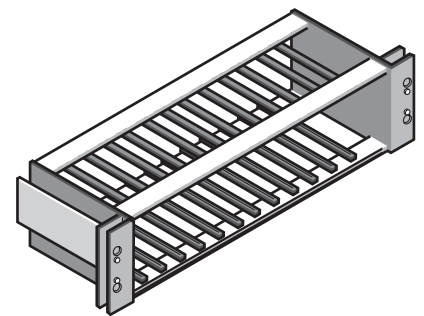

Frame Interconnection Module

LBB 2505/10

- For connecting a Booster Frame to a Module Extension Frame
- Single width module inserted in the MXF
- Cables and connectors supplied

Supplied with:

- Installation instructions
- Safety instructions
- 15-pole mini D-type (male) to 15-pole mini D-type (female) cable
- 15-pole mini D-type (female) to 16-pole IDC system cable

Booster Connection Board

LBB 2503/00 (BCB)

- Emulates SQ 45 Booster Amplifiers
- Transformer balanced inputs
- Galvanically separated inputs and outputs
- Can operate with external 20 kHz supervision pilot tone
- Used in combination with SM 30 and SM 40 sound management systems

The Booster Connection Board is used to make the SM 25B Booster Frames compatible with SQ 45 booster amplifiers in SM 30 and SM 40 system configurations.

Supplied with:

- Installation and safety instructions

SM 25B SOUND MANAGEMENT

10. Accessories

Type no.	Description	Code
LBC 1500/00	Table-top set	TTS
LBC 1501/00	Hand-grip set	HGS
LBC 1502/00	Blank Panel Set	BPS
LBC 1510/10	Call Station Connection Cable	CCC
LBC 1520/10	Call Station Cable Reel	CCR

Table-Top Set LBC 1500/00 (TTS)

The LBC 1500/00 Table-top Set is a metal housing for a single Booster Frame in table-top applications.

Technical data

Dimensions in mm (H x W x D): 140 x 452 x 370

Weight: 1.2 kg

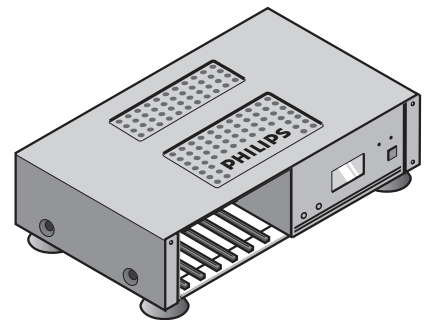

Supplied with:

- Installation instructions
- Detachable feet

Hand-Grip Set LBC 1501/00 (HGS)

The LBC 1501/00 is a pair of hand grips for the SM 25B Booster Frame (or Module Extension Frame) in table-top or rack-mounted installations.

Supplied with:

- Installation instructions
- Fixing screws

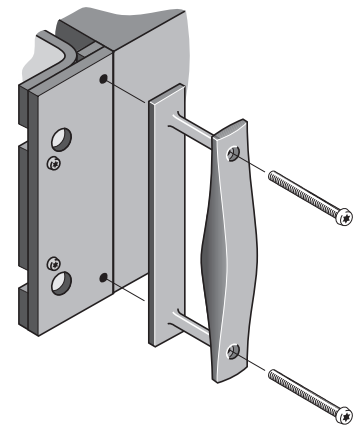

Blank Panel Set LBC 1502/00 (BPS)

The LBC 1502/00 is a set of three blank module front panels for unused positions in the Booster Frame (or Module Extension Frame). The BPS contains a single-width, double-width and triple-width blanking panel.

Supplied with:

- Installation instructions
- Fixing screws

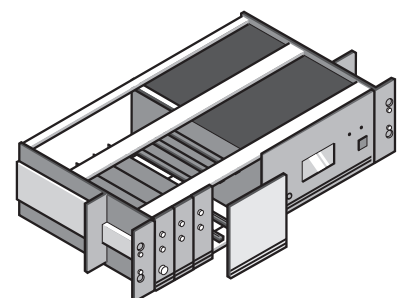

SM 25B SOUND MANAGEMENT

10. Accessories

Call Station Connection cable

LBC 1510/10 (CCC)

- 10 m long cable
 - terminated at both ends with 8-pole male DIN connectors
 - For joining a CSM to a CS-B, or a CS-B to a CS-B
 - Screened cable with four twisted pairs (0.14 mm²)
-

Call Station Cable Reel (100 m)

LBC 1520/10 (CCR)

- 100 m long reel of cable
- For joining a CSM to a CS-B, or a CS-B to a CS-B
- Screened cable with four twisted pairs (0.14 mm²)
- Supplied without connectors

Recommended cable specifications

The recommended cable for connecting Call Stations to the CSM is a screened cable containing three twisted pairs of 0.2 mm² cross-sectional area copper conductors (equivalent to a 0.5 mm diameter solid conductor). The three cable pairs are used for power, signal and data. If the loop resistance does not exceed 200 Ω per km, the maximum cable length is 1 km.

SM 25 B SOUND MANAGEMENT

11. Configuration Examples

2-input mixing amplifier

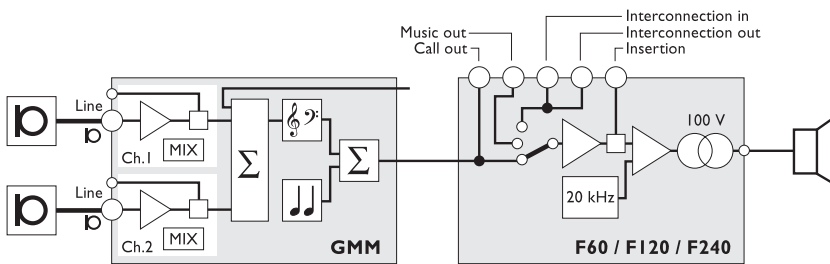
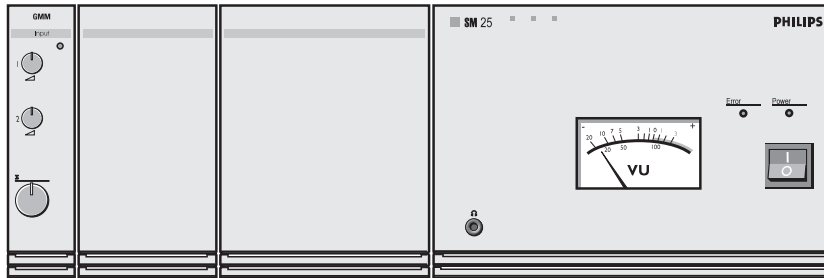

A two-input mixing amplifier requires a GMM and a Booster Frame (F60, F120 or F240).

4-input mixing amplifier with manual zone selection.

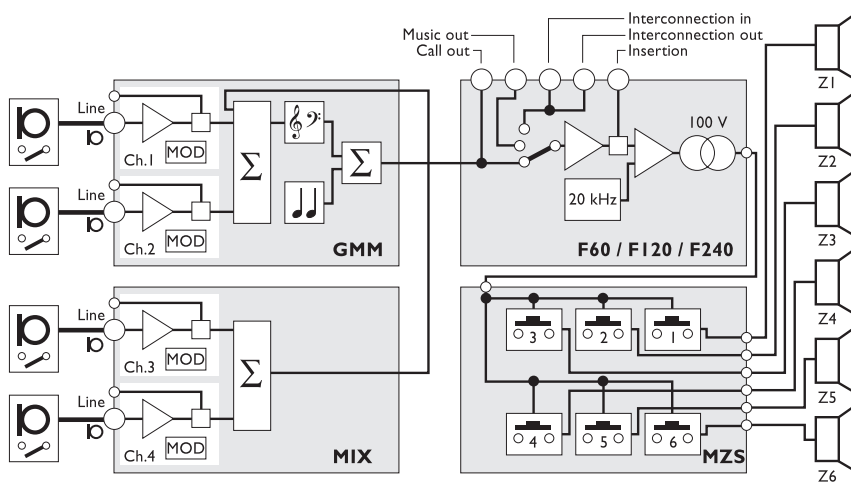
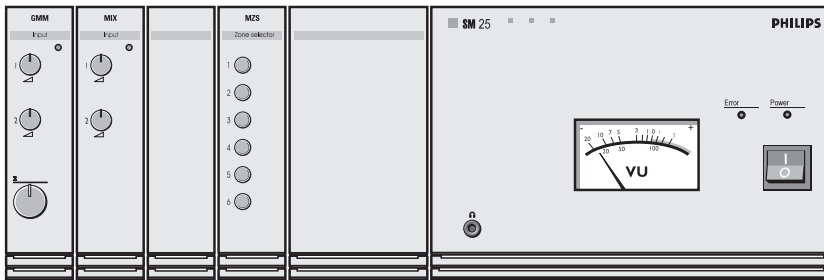

A four-input mixing amplifier with manual zone selection requires a GMM, MIX, MZS and a Booster Frame (F60, F120 or F240).

SM 25 B SOUND MANAGEMENT

11. Configuration Examples

10-input mixing amplifier

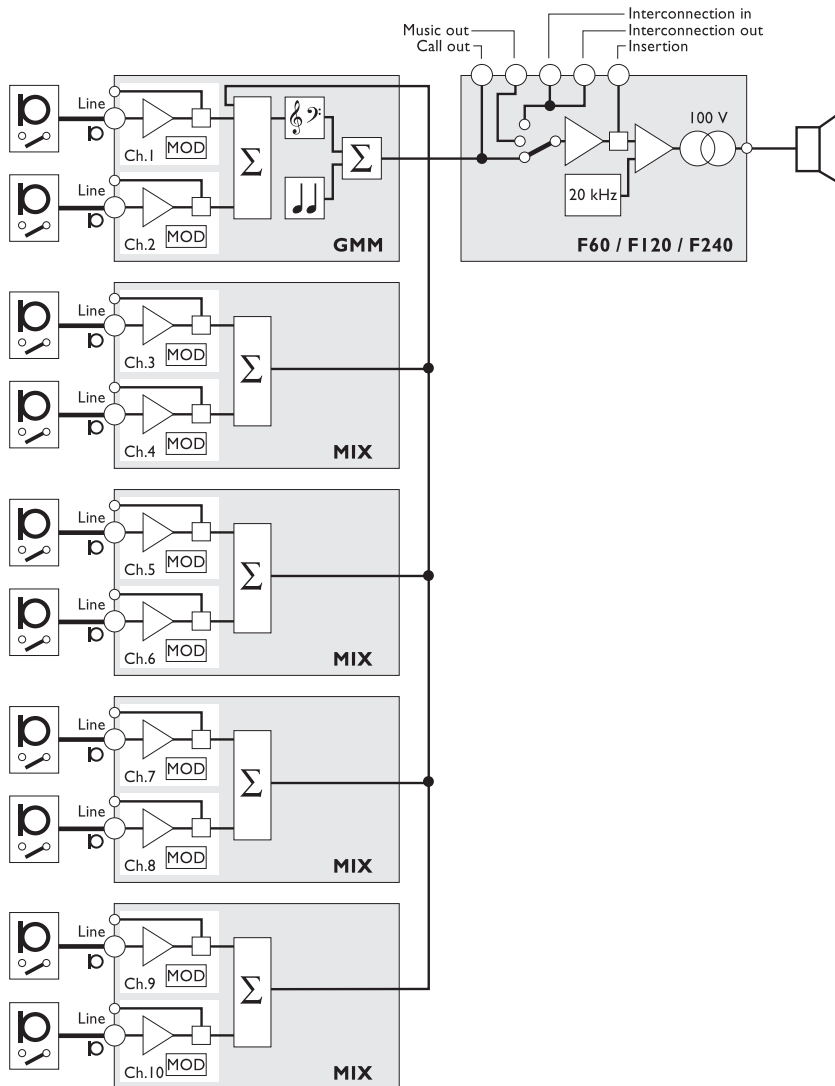
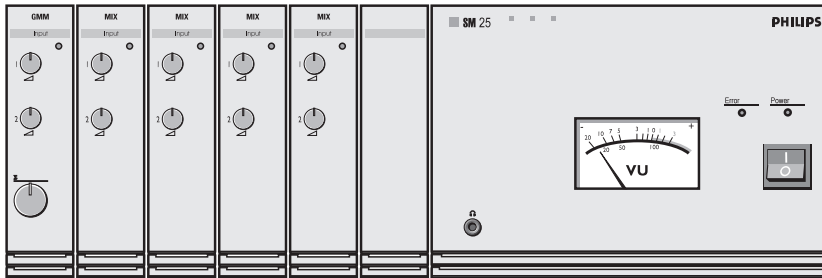

A ten-input mixing amplifier requires a GMM, 4 MIX, a BPS and a Booster Frame (F60, F120 or F240).

SM 25 B SOUND MANAGEMENT

11. Configuration Examples

Single-channel call amplifier

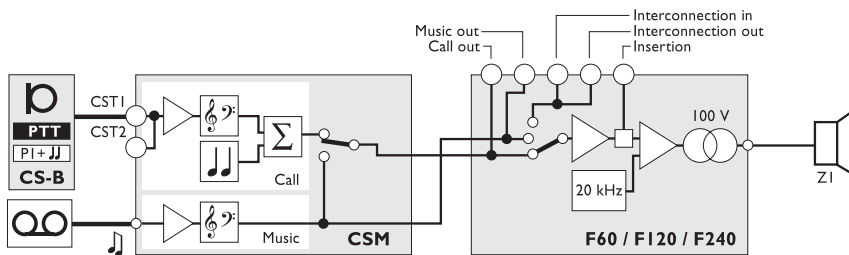
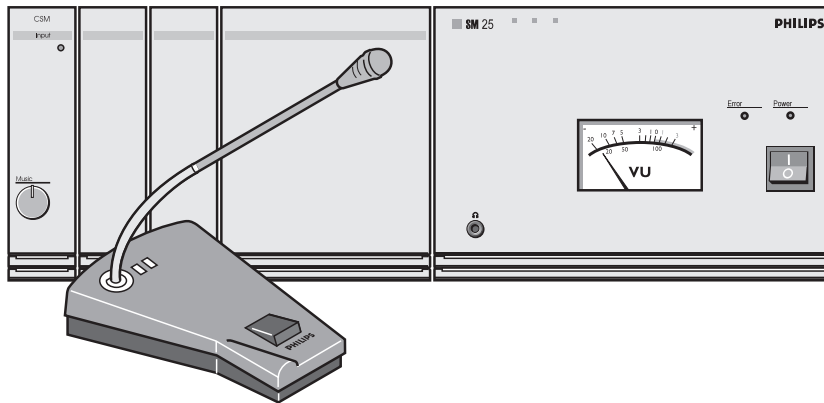

A single-channel call amplifier requires a CSM, CS-B, a PPS and a Booster Frame (F60, F120 or F240).

SM 25 B SOUND MANAGEMENT

11. Configuration Examples

Single-channel call system with manual zone selection

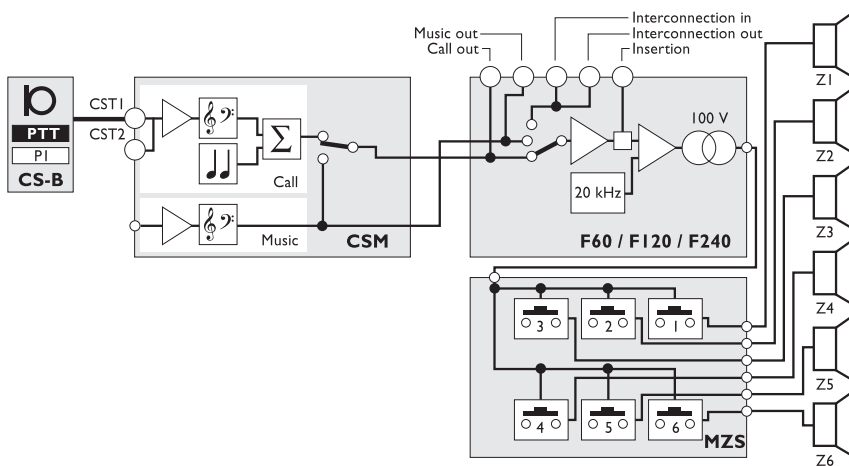

A single-channel call amplifier with manual zone selection requires a CSM, CS-B, MZS, a BPS and a Booster Frame (F60, F120 or F240).

SM 25 B SOUND MANAGEMENT

11. Configuration Examples

2-channel call amplifier with 12 automatically selected zones

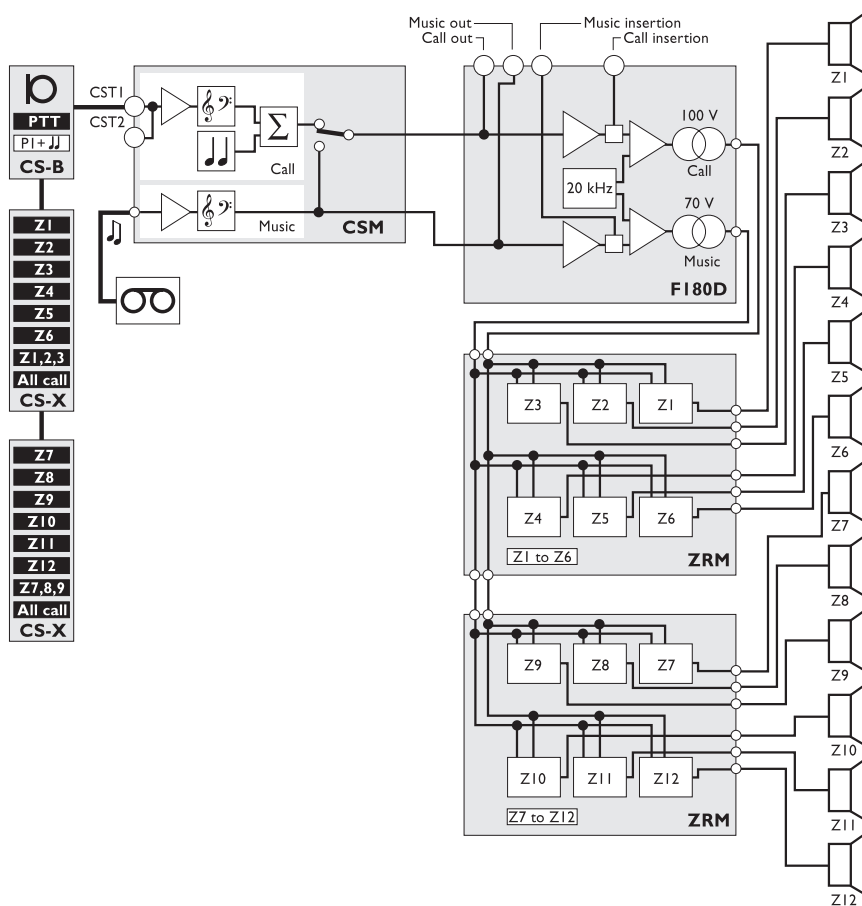
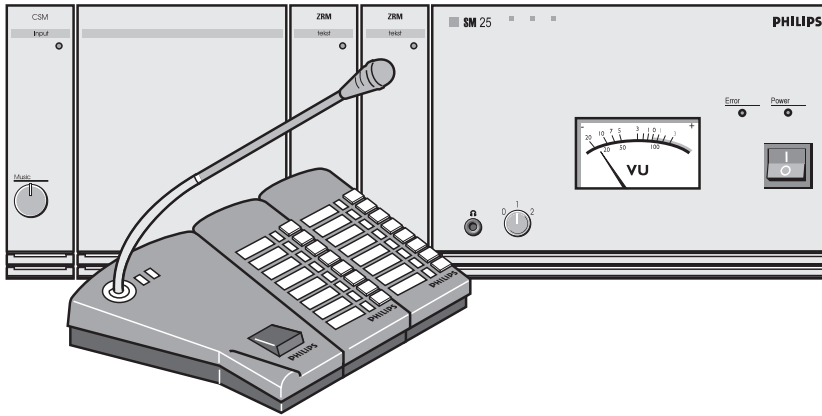

A two-channel call amplifier (music and call) requires a CSM, CS-B with two CX-B, a BPS and a dual-amplifier Booster Frame (F180D).

SM 25B SOUND MANAGEMENT

12. Index

Alphanumeric index

Product description	Code	Type number	Page
60 W Booster Amplifier	B60	LBB 2106/00	3.3
120 W Booster Amplifier	B120	LBB 2112/00	3.3
240 W Booster Amplifier	B240	LBB 2124/00	3.3
60 W Booster Frame	F60	LBB 2006/00	3.3
120 W Booster Frame	F120	LBB 2012/00	3.3
60 W and 120 W Booster Frame	F180D	LBB 2018/00	3.4
240 W Booster Frame	F240	LBB 2024/00	3.3
Alarm Routing Module	ARM	LBB 2540/10	7.2
Blank Panel Set	BPS	LBC 1502/00	10.1
Booster Carrier Frame	BCF	LBB 2100/00	3.1
Booster Connection Board	BCB	LBB 2503/00	9.1
Call Station Basic	CS-B	LBC 2500/10.....	5.2
Call Station Cable Reel	CCR	LBC 1520/10	10.2
Call Station Connection Cable	CCC	LBC 1510/10	10.2
Call Station Extension	CX-B	LBC 2502/10.....	5.3
Call Station Module	CSM	LBB 2511/10	6.6
Frame Interconnection Module	FIM	LBB 2505/10	9.1
General Mixing Module	GMM	LBB 2510/20	6.2
Hand-Grip Set	HGS	LBC 1501/00	10.1
Manual Zone Switch	MZS	LBB 2550/00	8.3
Mixing Input Module	MIX	LBB 2516/10	6.3
Module Extension Frame	MXF	LBB 2500/00	9.1
Power Supply Module	PSM	LBB 2502/10	4.1
Recordable Message Module	RMM	LBB 2541/10	7.4
Table-Top Set	TTS	LBC 1500/00	10.1
Tuner Module	TUM	LBB 2521/10	7.6
Zone Relay Module	ZRM	LBB 2551/10	8.2

SM 25B SOUND MANAGEMENT

12. Index

Type number index

Type number	Product description	Code	Page
LBB 2006/00	60 W Booster Frame	F60.....	3.3
LBB 2012/00	120 W Booster Frame	FI20.....	3.3
LBB 2018/00	60 W and 120 W Booster Frame	FI80D.....	3.4
LBB 2024/00	240 W Booster Frame	F240.....	3.3
LBB 2100/00	Booster Carrier Frame	BCF.....	3.1
LBB 2106/00	60 W Booster Amplifier	B60.....	3.3
LBB 2112/00	120 W Booster Amplifier	B120.....	3.3
LBB 2124/00	240 W Booster Amplifier	B240.....	3.3
LBB 2500/00	Module Extension Frame	MXF.....	9.1
LBB 2502/10	Power Supply Module	PSM.....	4.1
LBB 2503/00	Booster Connection Board	BCB.....	9.1
LBB 2505/10	Frame Interconnection Module	FIM.....	9.1
LBB 2510/20	General Mixing Module	GMM.....	6.2
LBB 2511/10	Call Station Module	CSM.....	6.6
LBB 2516/10	Mixing Input Module	MIX.....	6.3
LBB 2521/10	Tuner Module	TUM.....	7.6
LBB 2540/10	Alarm Routing Module	ARM.....	7.2
LBB 2541/10	Recordable Message Module	RMM.....	7.4
LBB 2550/00	Manual Zone Switch	MZS.....	8.3
LBB 2551/10	Zone Relay Module	ZRM.....	8.2
LBC 1500/00	Table-Top Set	TTS.....	10.1
LBC 1501/00	Hand-Grip Set	HGS.....	10.1
LBC 1502/00	Blank Panel Set	BPS.....	10.1
LBC 1510/10	Call Station Connection Cable	CCC.....	10.2
LBC 1520/10	Call Station Cable Reel	CCR.....	10.2
LBC 2500/10	Call Station Basic	CS-B.....	5.2
LBC 2502/10	Call Station Extension	CX-B.....	5.3

SM 25B SOUND MANAGEMENT