

- MICROPROCESSOR CONTROL ALLOWS A WIDE VARIETY OF ROUTING AND SWITCHING OPERATIONS TO BE EXECUTED QUICKLY, EFFICIENTLY AND RELIABLY •
- MONITORS THE STATUS OF PA SYSTEM AMPLIFIERS, LOUDSPEAKERS AND CABLING •
- MICROPROCESSOR CONTROL ALLOWS SPECIFIC FUNCTIONS TO BE EASILY AND SPEEDILY PROGRAMMED BY NON-TECHNICAL PERSONNEL •
- RACK-MOUNTED EURO CARD CIRCUIT BOARDS MAKE SYSTEM EXPANSION AND ALTERATION EASY AND ECONOMICAL •
- BASIC SYSTEM IS SELF-CONTAINED IN A 19 INCH RACK FRAME, FULLY WIRED, TESTED AND READY FOR USE •

The SM40 Distribution System is developed to meet the demand for a comprehensive, yet simple to operate, sound distribution system. In such large public address distribution systems, which often play a role in alarm and evacuation installations, it is vital that the correct functioning of the various amplifiers and loudspeakers can be verified. Therefore, the SM40 Surveillance System is designed to monitor the status of the amplifiers, loudspeakers and cables. Since it pinpoints any failures in the system, it saves a great deal of time, minimising the repair costs and ensuring that the system is fully functional at the earliest possible moment.

Being controlled by microprocessors, the systems are particularly flexible: all routing, switching and priority functions, and surveillance requirements can easily be programmed and changed by non-technical personnel. The Basic System is the heart of each system and is a fully working, self-contained unit in its own right. If supplemented with a variety of circuit cards, a wide range of system configurations is possible and many different application needs are successfully met.

Distribution System

The Distribution Basic System is fed by professional microphones mounted on Call Stations as well as auxiliary music sources. Each Call Station contains up to 10 User Keys, which can be programmed to route the microphone calls, digitally stored messages, attention tones or alarm signals to one or several power amplifiers. These amplifiers in turn, feed the loudspeakers located in the geographical and/or functional zones where people must be reached with background music, announcements or alarm signals.



LBB I350 and LBB I370 range

SM40 DISTRIBUTION AND SURVEILLANCE SYSTEMS

Surveillance System

The Surveillance System is able to scan the presence of the pilot tone signal in monitoring devices, located at strategic places (at amplifier outputs, loudspeaker cabling junction boxes, inside loudspeaker enclosures) throughout a large distribution system. At detection of a malfunction, an error message is automatically generated, giving the precise time and location of the fault. It can also receive 'internal error' information from the system itself.

A maximum configuration of the Surveillance System is able to sequentially scan 32 test lines, connecting up to 4,096 monitoring devices; receive error input from 11 external sources; and activate 32 relay sets.

SPECIFICATIONS

LBB I350 and LBB I370 range

SM40 DISTRIBUTION AND SURVEILLANCE SYSTEMS

Table of Contents

I	INTRODUCTION	PAGE 78
2	SURVEY OF THE BASIC SYSTEMS	79
2.1	Distribution Basic System	79
2.2	Extension Frame	79
2.3	Surveillance Basic System	80
2.4	Main Block Diagram	81
3	CALL STATIONS	82
3.1	Call Station (standard version)	82
3.2	Extended Call Station	83
3.3	Master Call Station	83
3.4	Alarm Station	84
3.5	Optional printed circuit boards	84
3.5.1	- Key Sensing PCB	84
3.5.2	- Microphone Amplifier PCB	85
3.5.3	- Key Confirmation PCB	85
3.5.4	- Call Station Microphone Assembly	85
4	COMMON SYSTEM CARDS AND BOARDS	86
4.1	Interconnection Board	86
4.2	Termination Board	86
4.3	Display and Keyboard	86
4.4	Control Relay Card	87
5	CARDS FOR THE DISTRIBUTION SYSTEM	88
5.1	Distribution Basic System	88
5.1.1	- Input Card	88
5.1.2	- Central Processor Card	89
5.1.3	- Signal Generator Card	90
5.1.4	- Matrix Card	91
5.1.5	- Matrix Termination Board	91
5.2	Optional cards	92
5.2.1	- Tone Control Card	92
5.2.2	- Signal Processing Card	92
5.2.3	- Automatic Volume Control Card	93
5.2.4	- ANDAP application	95
5.2.5	- Digital Message Card	96
5.2.6	- I/O-PCB	97
6	CARDS FOR THE SURVEILLANCE SYSTEM	98
6.1	Surveillance Basic System	98
6.1.1	- Central Processor Card + I/O	98
6.1.2	- Pilot tone Generator Card	99
6.1.3	- Surveillance Switch Card	100
6.2	Separate printed circuit boards	101
6.2.1	- Loudspeaker Surveillance Board	101
6.2.2	- Amplifier Surveillance Board	102
7	SPECIFICATION	103
7.1	General	103
7.2	Card Supply	103
7.3	Audio Signal Data	104
7.4	Call Station Characteristics	105
7.5	Audio Signal Level Diagram	106

SPECIFICATIONS

LBB I350 and LBB I370 range

SM40 DISTRIBUTION AND SURVEILLANCE SYSTEMS

I. INTRODUCTION

The SM40 basic unit is a self-contained, fully operational system into which all other SM40 circuit cards can be fitted. It can comprise up to 10 circuit cards, to be mounted in a single 19" rack frame. All the inputs of the circuit cards are protected against overvoltage and short circuiting.

The unit has a self-monitoring system for internal faults.

When used as a starter Distribution Basic System, it has a large range of possibilities for sound distribution, routing and switching. Used as a starter Surveillance Basic System, it is capable to monitor the status of loudspeakers, amplifiers and cables in large sound systems. Both systems can be combined with amplifiers from the SQ45 range to form a sophisticated Public Address system.

Each Basic System can be expanded to a comprehensive system by applying extra circuit cards. A wide range of system configurations are possible and many different needs are successfully met.

All Basic System internal wiring is particularly installer friendly due to the use of the 'quick fit' connectors. Since the Basic System is delivered fully wired, adjusted, tested, and mounted in a 19" rack frame, ready for use, it is an ideal base for large systems. An Extension Frame is available to accommodate all the circuit cards when the quantity of required cards in the system exceeds the amount of space offered in the basic rack frame.

All the rack frames and the amplifiers can be fitted into a 19 inch rack cabinet.

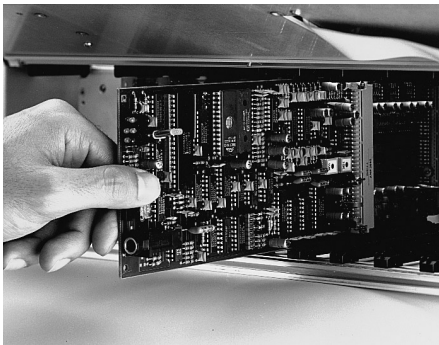

SPECIFICATIONS

LBB I350 and LBB I370 range

SM40 DISTRIBUTION AND SURVEILLANCE SYSTEMS

2. SURVEY OF THE BASIC SYSTEMS

2.1 DISTRIBUTION BASIC SYSTEM LBB I350/30

The Distribution Basic System is fed by professional microphones mounted on Call Stations as well as auxiliary music sources. Each Call Station contains up to 10 User Keys, which can be programmed to route the microphone calls, attention tones or alarm signals to the individual (or a combination of) power amplifiers. These amplifiers feed the loudspeakers located in the geographical and/or functional zones where people must be reached with background music, announcements or alarm signals.

If used in applications with minimal requirements, a maximum of 3 Call Stations can be connected to the system. It is capable of controlling 8 amplifiers which in turn feed a maximum of 8 loudspeaker zones.

In a maximum configuration, the Distribution System can accept (via a 16 x 64 matrix) up to 16 audio inputs to feed up to 64 individual amplifier inputs, or (via a 32 x 32 matrix) up to 32 audio inputs to feed up to 32 amplifiers.

Separate printed circuit boards are available to build a variety of stations:

- ECS Extended Call Station
- MCS Master Call Station
- AST Alarm Station

Please refer to the description of the Call Station for more information.

2.2 EXTENSION FRAME LBB I360/30

This single 19 inch rack frame is capable of holding 10 SM40 circuit cards. It can be used in a SM40 system when the quantity of cards required, or the amount of Termination Boards available, exceeds the amount of space offered in the Basic System rack frame.

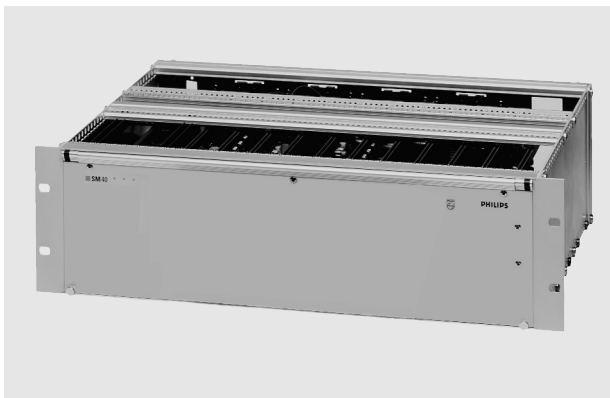

The Distribution Basic System comprises:

1x	Single 19" rack frame	
1x	Power Supply +15V/-15V/+5V	
1xIB	Interconnection Board	
2xTB	Termination Boards	LBB I377/00
1xMTB	Matrix Termination Board	LBB I371/00
1xDK	Display and Keyboard	
1xCPC	Central Processor Card	LBB I352/30
	Distribution System Software	
1xCRC	Control Relay Card	LBB I356/00
1xIPC	Input Card	LBB I351/00
1xSGC	Signal Generator Card	LBB I354/00
1xMC	Matrix Card	LBB I355/00

Optional cards:

TCC	Tone Control Card	LBB I357/00
SPC	Signal Processing Card	LBB I358/00
AVC	Automatic Volume Control Card	LBB I359/00
		-/09-/21
DMC	Digital Message Card	LBB I378/00
I/O	I/O-PCB	LBB I375/30
MTB	Matrix Termination Board	LBB I371/00
CRC	Control Relay Card	LBB I356/00
IPC	Input Card	LBB I351/00
SGC	Signal Generator Card	LBB I354/00
MC	Matrix Card	LBB I355/00
TB	Termination board	LBB I377/00
RTB	Relay Termination board	LBB I379/00

Optional units:

CST	Call Station (standard version)	LBB 9567/30
-----	---------------------------------	-------------

An Extension Frame comprises:

1x	Single 19" rack frame	
1x	Power Supply +15V/-15V	
1xIB	Interconnection Board	
1xTB	Termination Boards	LBB I377/00

SPECIFICATIONS

LBB I350 and LBB I370 range

SM40 DISTRIBUTION AND SURVEILLANCE SYSTEMS

2.3 SURVEILLANCE BASIC SYSTEM LBB I370/30

A pilot tone signal is generated which is inserted into the Test inputs of the Philips SQ45 power amplifiers series. The Surveillance System is able to scan the presence of this signal in monitoring devices, located at strategic places (at amplifier outputs, loudspeaker cabling junction boxes, inside loudspeaker enclosures) throughout a large distribution system.

On detection of a malfunction, an error message is automatically generated, giving the precise time and location of the fault.

The message can either be relayed to the LCD display of the system, or sent to either a personal computer or an external printer for a permanent hard copy record of the malfunction. The message can also be linked to warning lamps, buzzers, or personnel paging units to alert security and maintenance personnel. Even the possibility exists to switch-in automatically a standby amplifier in place of an amplifier which becomes faulty.

External sensors, such as smoke detectors and micro switches, can also be connected to the system, which in turn can activate the relays on the Control Relay Card.

If the Basic System becomes faulty itself, an 'internal error' message is generated.

Normal two core screened microphone cable can be used to carry the data and power between the system and the interlinked Amplifier and Loudspeaker Surveillance Boards.

Being supplied with 1 Surveillance Switch Card, the Surveillance Basic System is able to scan 8 separate test lines, each linked to (up to) 128 Amplifier and/or Loudspeaker Surveillance Boards. It is also able to display error information generated by 3 external sources.

A maximum configuration of the Surveillance System is able to sequentially scan 32 test lines connecting up to 4,096 monitoring devices; receive error messages from 12 external sources; and activate 32 relay sets.

The Surveillance Basic System comprises:

1x	Single 19" rack frame	
1x	Power Supply +15V	
1x	Power Supply +15V/-15V/+5V	
1xIB	Interconnection Board	
4xTB	Termination Boards	LBB I377/00
1xCPC	Central Processor Card +I/O Surveillance System Software	
1xCRC	Control Relay Card	LBB I356/00
1xSSC	Surveillance Switch Card	LBB I374/00
1xPGC	Pilot tone Generator Card	LBB I369/00

Optional cards:

CRC	Control Relay Card	LBB I356/00
SSC	Surveillance Switch Card	LBB I374/00
PGC	Pilot tone Generator Card	LBB I369/00
TB	Termination Board	LBB I377/00

Optional separate printed circuit boards:

LSB	Loudspeaker Surveillance Board	LBB I367/00
ASB	Amplifier Surveillance Board	LBB I368/00



SPECIFICATIONS

LBB I350 and LBB I370 range

SM40 DISTRIBUTION AND SURVEILLANCE SYSTEMS

2.4 MAIN BLOCK DIAGRAM

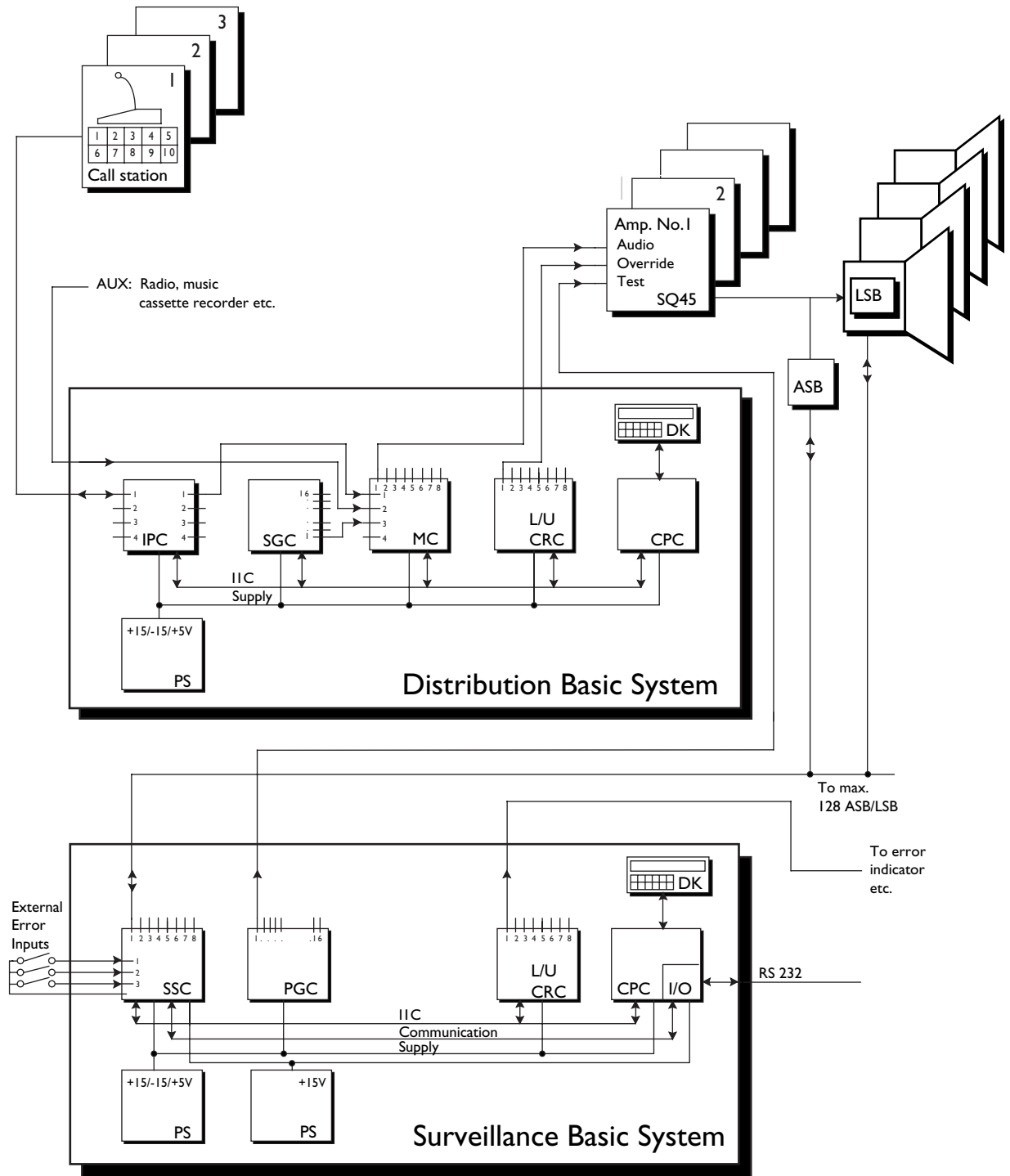

SPECIFICATIONS

LBB I350 and LBB I370 range

SM40 DISTRIBUTION AND SURVEILLANCE SYSTEMS

3. CALL STATIONS

3.1 CALL STATIONS - CST (STANDARD VERSION)

LBB 9567/30

Main data

- Part of the Distribution System
- High quality microphone
- Pre-set gain control with built-in limiter
- Bass rolloff-filter
- 10 User Keys

Correlation with other cards

Input : -
Output: Input Card
Others: -

Max. number of stations in the system

15 Call Stations when a 16x64 matrix is used.

31 Call Stations when a 32x32 matrix is used.

If music inputs and/or Signal Generator Cards are used in the system, less stations can be connected.

Operation

This standard **Call Station** is a desktop model, provided with a high quality microphone mounted on a goose-neck.

A **Keyboard** is available for selecting the following User Key functions: Key Priority, Signal Tones plus pre-recorded messages and Routing. These functions are programmed in the microprocessor and can be activated by pushing just one of the push buttons.

Key Priority Level can be set to give each key a priority of 0-9 to cope with conflict situations (e.g. two stations attempting to call the same zone simultaneously). The caller with the highest priority (9) overrides any lower priority callers and they are warned of this status by the 'busy' LED.

Signal tones are available to precede an announcement (attention tones). Depending on their character; however, they may be used as alarm or test tones.

Pre-recorded messages: see also chapter 5.2.5 Digital Message Card.

Routing assigns a User Key to one or more amplifiers which feed the loudspeakers in geographical or functional zones.

Two **Led Indicators** are mounted in the front panel to advise the user whether the selected zone is clear to call. The green LED is titled 'wait and talk' and the red LED 'busy'.

The **Amplifier** in the Call Station has a double function. It provides the call station microphone with a 60 Ohm (balanced) line level output, enabling it to use a normal 2 core twisted screened microphone cable with a length of up to 1,000 metres. Furthermore, it generates the User Key address code.

The volume level is controlled by a limiter and each Call Station has a volume level pre-adjustment.

The bass rolloff-filter slope may be increased to aid clarity when the caller is forced to speak close to the microphone because of high background noise. An announcement signal normally mutes any music being fed to the called zone, but the facility exists to merely reduce the music volume with -10 dB while the announcement comes through at full volume.

To meet specific user requirements, special call stations can be built with separate printed circuit boards. These boards can be mounted into cabinets or desks and other suitable enclosures. The following are available for these applications:

CSA	Call Station Microphone Assembly
MAP	Microphone Amplifier PCB
KSP	Key Sensing PCB
KCP	Key Confirmation PCB

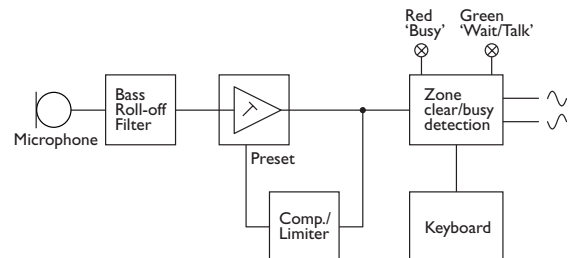

SPECIFICATIONS

LBB I350 and LBB I370 range

SM40 DISTRIBUTION AND SURVEILLANCE SYSTEMS

3.2 EXTENDED CALL STATION - ECS

Main data

- Built-up with separate PCBs
- Same functions as standard Call Station
- 50 User Keys maximum.

Operation

A standard Call Station has 10 User Keys. If you want more User Keys an Extended Call Station can be assembled.

In this type of station up to 5 Key Sensing PCBs may be connected to 1 Microphone Amplifier PCB. The station operates in the same way as a standard call station, but has 50 User Keys.

A maximum of 4 Extended Call Stations may be used in the Distribution System, resulting in a maximum of 200 User Keys.

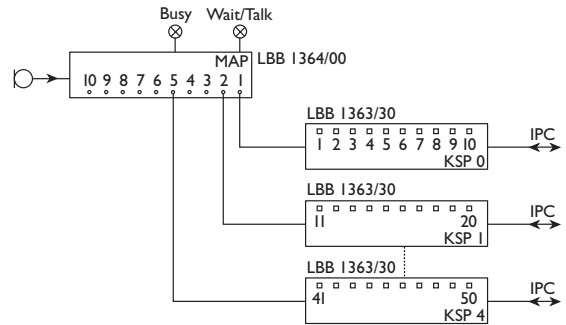

3.3 MASTER CALL STATION - MCS

Main data

- Built-up with separate printed circuit boards
- 10 Activation Keys for chime and priority/talk keys
- 90 Pre-selection User Keys for zone/zone-group selection
- Key confirmation indication lights

Operation

In a Master Call Station, there is the possibility to pre-select the loudspeaker zone to be called.

In this type of station, the first Key Sensing PCB and the Microphone Amplifier PCB are the activation section.

The keys can be used in two modes. In the separate mode, keys 1-5 are used as 5 chime selection keys, keys 6-9 as priority/talk keys and key 10 as a reset key.

In the combined mode, keys 1-9 are used as a combination of chime/priority keys and key 10 as reset key.

The other Key Sensing PCBs are the pre-selecting section, consisting of up to 9 Key Sensing PCBs with 90 User Keys.

By using a Key Confirmation PCB, or the I/O PCB it is possible to indicate the preselection User Keys which are at that moment active. A LED or a built-in indication light, powered with a separate power supply, acts as an indicator.

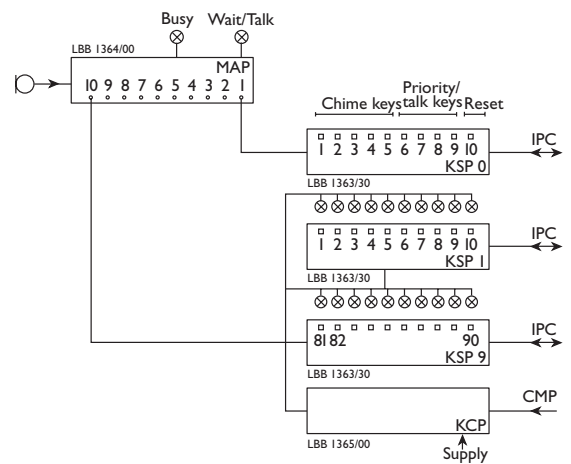

SPECIFICATIONS

LBB I350 and LBB I370 range

SM40 DISTRIBUTION AND SURVEILLANCE SYSTEMS

3.4 ALARM STATION - AST

Main data

- Built-up with separate PCBs
- Activated by 10 individual remote make contacts

Operation

In an Alarm Station the Key Sensing PCB can be used to activate alarm tones. Instead of using the keys on the board for a call, individual make contacts can be connected to the board. These contacts may be remote contacts from smoke-detectors, a security system, etc.

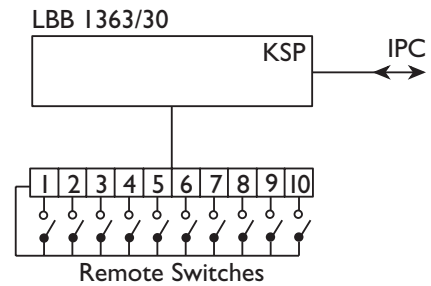

3.5 OPTIONAL PRINTED CIRCUIT BOARDS

3.5.1 Key sensing PCB - KSP LBB I363/30

Main data

- Separate PCB with 10 buttons to expand the number of User Keys
- Key detection and switching
- Board dimensions 4 x 18 cm

Correlation with other cards

Input: Microphone Amplifier PCB Closed/open contact of a detector
 Output: Input Card
 Others: Central Processor Card

Operation

This separate board has 10 User Keys and it informs the Central Processor Card which User Key is being pressed, so that the call-signal from the Microphone Amplifier PCB can be routed to the programmed zone. The buttons can be mounted onto the board in 2 blocks of 5 buttons or connected via a flat cable for remote control purposes.

To allow key sensing of the board, the ON/OFF master switch located on the Microphone Amplifier PCB can be set in the 'active' or 'non-active' mode by means of a jumper.

Key Sensing PCBs can be used in Extended Call Stations, Alarm Stations or Master Call Stations.

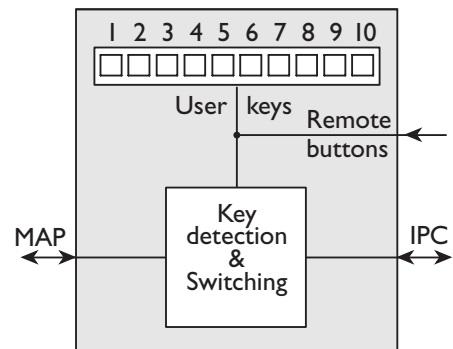

SPECIFICATIONS

LBB I350 and LBB I370 range

SM40 DISTRIBUTION AND SURVEILLANCE SYSTEMS

3.5.2 Microphone amplifier pcb - map LBB I364/00

Main data

- Separate PCB to be used as microphone amplifier in Extended Call Stations or Master Call Stations
- Board dimensions 6 x 18 cm

Correlation with other cards

Input: Microphone Key Sensing PCB
 Output: Key Sensing PCB

Operation

This board contains a bass rolloff-filter, a compressor limiter and a volume control, but it differs from the amplifier board used in the standard Call Station on the following points.

Phantom powering is available, so that both a dynamic microphone and a condenser microphone can be used. A switch is mounted for selecting either balanced or unbalanced microphone inputs.

Additional soldering pins are mounted for connecting a VU-meter or a headphone.

Master ON/OFF key-switch contacts (make contact) and telephone handset cradle switch contacts (break contact) are available to enable key sensing. These key sensing functions can be set in the 'active' or 'non-active' mode by two jumpers on the corresponding Key Sensing PCB.

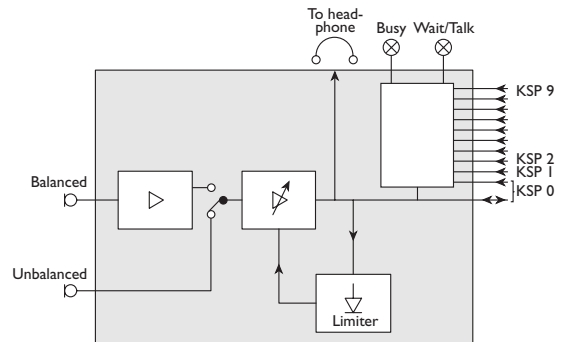

3.5.3 Key confirmation PCB - KCP LBB I365/00

Main data

- Separate PCB to indicate (e.g. illuminate) the currently active User Keys in a Master Call Station
- Board dimensions 10 x 18 cm

Correlation with other cards

Input: Communications PCB
 Output: Indicator; e.g. LED or lamp
 Others: Central Processor Card

Operation

To show which User Key is currently active, it is possible to use an illuminated button or a LED indicator which can be activated via this board. After detection by the Central Processor of the activation of a User Key, a signal is sent via the Communications PCB to the Key Confirmation PCB which in turn powers the relevant LED or light.

A maximum of 4 boards may be used in the system to activate up to 160 indicators.

Note: Because of the amount of the power used by the LEDs or lights, a separate power supply (+15V or +5V) has to be used.

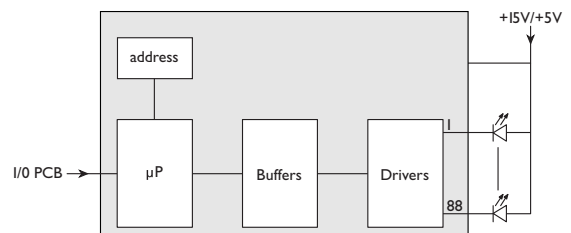

3.5.5 Call station microphone assembly - CSA LBB 9560/30

Main data

- Part of a Call Station
- Microphone with goose neck

Correlation with other parts

Input: -
 Output: Microphone Amplifier PCB
 Others: -

Operation

This assembly can be used to build your own Call Station. It comprises of a high quality cardioid microphone and a flexible 'goose neck' with a mounting base.

LBB I350 and LBB I370 range

SM40 DISTRIBUTION AND SURVEILLANCE SYSTEMS

4. COMMON SYSTEM CARDS AND BOARDS

4.1 INTERCONNECTION BOARD - IB

Main data

- Board in the Basic System to interconnect 10 SM40 Eurocards
- Eurocard a+b connectors (2x32 poles)

Operation

An interconnection board provides the system with both reliability and a great deal of flexibility. Each connector on the board is the same, so that the SM40 cards may be located in the most convenient order within the frame.

The power supply and the reference signals common to all of the circuit cards, is linked via a rail system on the board. Since the system has such a wide range of configuration possibilities, cross-wiring between the circuit cards is necessary. This is easily accomplished by terminating the individual wires or flat cables with female connectors, which can be pushed onto the connector pins on the rear side of the board. The interconnection between the Interconnection Board and the Termination Boards is also accomplished using flat cables fitted with female connectors.

To allow for certain contacts of adjacent cards to be joined together, connector blocks (2 x 8) have been added between the 10 connectors. Soldering is not to be carried out using small jumper plugs.

It should be noted that in the maximum system all cards controlled by the Central Processor Card must be mounted in the first 6 frames.

4.2 TERMINATION BOARD - TB LBB I377/00

Main data

- Board in the Basic System for connecting external wiring
- 2 x 16 screw block connector

Operation

The connections between the system and the peripheral equipment are linked via the Termination Board.

Each Termination Board is connected to the Interconnection Board by a flat cable and/or individual wires fitted with female connectors.

The screw connector blocks are plugged into sockets mounted on the board. This has the advantage that, if for any reason a system rack frame or a termination board has to be removed, the screw connector block can be simply unplugged leaving the peripheral equipment wiring intact.

4.3 DISPLAY AND KEYBOARD - DK

Main data

- Mounted in the front panel of the Basic System
- 24 key keyboard
- 2 x 40 character LCD display

Operation

Users of an SM40 system can program and change the functions of their system quickly by means of the Display and Keyboard.

The unit can be flipped until it locks in the horizontal position to have a good access to the keys and a good view on the display.

Depending on the software, the keys have different functions in the Distribution and Surveillance System.

SPECIFICATIONS

LBB I350 and LBB I370 range

SM40 DISTRIBUTION AND SURVEILLANCE SYSTEMS

4.4 CONTROL RELAY CARD - CRC LBB I356/00

Main data

- Card in the Distribution and Surveillance Basic System
- Eurocard 10x22 cm with an 'ab' connector 2x32
- 8 Make and 8 break contacts
- Relays to be activated by the Central Processor Card

Correlation with other cards

Input: -
Output: Termination Board
Others: Central Processor Card

Max. number of cards in the system

Surveillance System: up to 5 cards
Distribution System: up to 4/8 'locked' cards and 12/8 'unlocked' cards

Operation

This card has 8 'make' and 8 'break' contacts which are activated by the Central Processor Card. The function switch 'locked' or 'unlocked' determines the operation of this card.

In the **Distribution System** the make contacts of the 'locked' cards are used to activate the loudspeaker volume control override relays and the break contacts to activate the 'priority' inputs of the SQ45 amplifiers. When an announcement or alarm is routed to a zone, the call or alarm signal will now be allowed to come through at its full level.

In this situation, each pair of the make and break relays is locked to one of the 8 outputs of the column. When a call or alarm signal is routed to that output, these relays will be automatically activated.

In the 'unlocked' situation, a number of extra functions become available to activate some of the relays, for system error indication, time related switching and routing, call stations busy etc.

In the **Surveillance System** the 'make' and 'break' contacts are used to switch on remote warning lights and buzzers or to activate a personal pager, etc. This feature is of great importance in situations where system faults must be clearly indicated and quickly investigated.

In the 'locked' situation, the card indicates errors on the corresponding Surveillance Switch Card test lines, so each relay indicates an error in its 'locked' zone.

In the 'unlocked' situation the card gives a number of useful error indications such as: system error, ASB or LSB error, external error and printing error.

The Control Relay Card position in the system and the way in which it relates to the Matrix Card columns, is defined by an 'address' accomplished by jumper setting on the card.

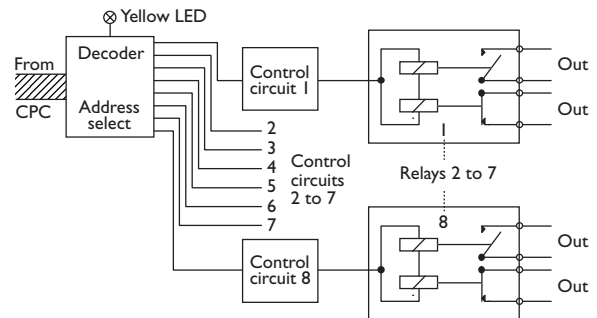

SPECIFICATIONS

LBB I350 and LBB I370 range

SM40 DISTRIBUTION AND SURVEILLANCE SYSTEMS

5. CARDS FOR THE DISTRIBUTION SYSTEM

5.1 OPTIONAL PRINTED CIRCUIT BOARDS

5.1.1 Input card - IPC LBB I351/00

Main data

- Card in the Distribution Basic System
- Eurocard 10x22 cm with an 'ab' connector 2x32
- 4 Inputs and outputs for Call Stations and/or Key Sensing PCBs
- Phantom powering to microphones
- User Key detection
- Amplifier gain preset from -10 to 0 dB

Correlation with other cards

- Input: Call Station
Key Sensing PCB
- Output: Matrix Card
Automatic Volume Control Card
Tone Control Card
Signal Processing Card
- Others: Central Processor Card

Max. number of cards in the system

8 Input Cards

Operation

This card usually interfaces Call Stations with the Distribution System and provides each station with:

- Microphone phantom powering
- Information for LED indication
- User Key detection

User Key detection is available for up to 10 keys which allows the Central Processor Card to detect the User Key being pressed on a particular Call Station. By coupling Input Cards, a Call Station can be extended to accept up to 50 user keys for extended call stations or even up to 100 user keys for master call station. User Keys can also be used without the 'call' facility to activate alarm tones and are then called Alarm Stations.

Each Input Card can be recognised by the Central Processor Card via an 'address' accomplished by jumper setting on the card.

Presetting of the amplifier gain is possible from -10 to 0 dB.

A short circuited input will not effect the other ones.

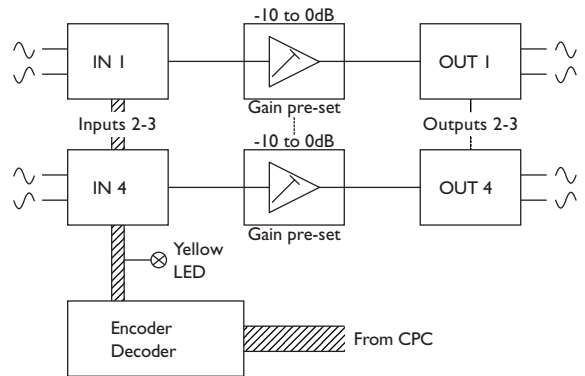

SPECIFICATIONS

LBB I350 and LBB I370 range

SM40 DISTRIBUTION AND SURVEILLANCE SYSTEMS

5.1.2 Central processor card -CPC LBB I352/30

Main data

- Card in the Distribution Basic System
- Eurocard 10x22 cm with an 'ab' connector 2x32
- Microprocessor controls via the I²C bus up to:
 - 15/31* Call Stations
 - 64/32* Loudspeaker circuits
 - 320 User Keys
 - 1024 Matrix points
 - 256 Relays
 - 8 Signal Generator Cards
 - 16 Digital Message Cards
- RAM memory 32k

* dependent on matrix configuration

Options

- I/O - PCB LBB I375/30

Operation

The Central Processor Card is the heart of the Distribution System and the basic functions are as follows.

Detection of User Keys in a Call Station. The card senses, in combination with the information given by the Input Card, which User Key has been pressed.

Routing the signals from the Input Cards via the Matrix Cards to the loudspeakers located in geographical and/or functional zones.

User Key priority level setting. When 2 Call Stations attempt to call the same zone simultaneously, a priority selection has to be made. To cope with these conflict situations, each User Key is given a priority level of 0-9 (9 is the highest priority).

Attention Signal Tones, selected by using this card, are coupled with the User Keys. When a key is pressed the tone will be broadcasted before an announcement or, dependent on their character, broadcasted as attention, alarm or test signal.

Switching of the loudspeaker volume control override circuits, and bypassing of the input attenuators in the SQ45 amplifiers via the Control Relay Card.

Also switching of the amplifier outputs for loudspeaker group switching, via 'unlocked' Control Relay Cards.

Checking of the system hardware. The processor is continuously guarding the system hardware for errors, malfunctions or disconnections. If a problem has been detected, a message will be displayed on the screen of the Display and Keyboard unit.

Real time clock functions. The date, hours and minutes are displayed on the screen of the Display and Keyboard unit. A timer facility is coupled to the

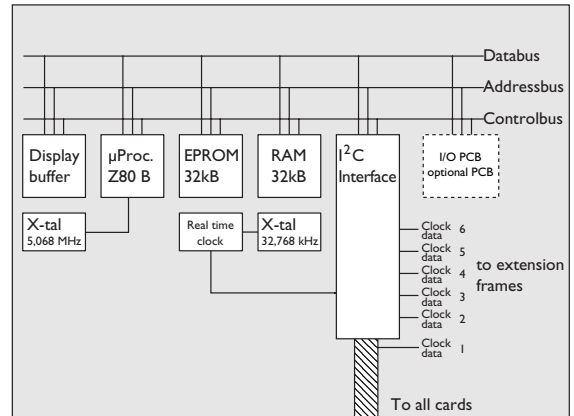

clock making it possible to switch on and route signals, pre-recorded messages, music, etc. at specific times of the day or week. Synchronisation of the real time clock is possible.

Programming of the microprocessor by the user has to be done via the Display and Keyboard unit. Having entered your password, you can change the programme.

Digital Message Card control allows you to record up to 16 x 65 seconds of speech.

Additional driver stages are mounted on the card for the I²C bus of up to 5 Extension Frames. Therefore, all circuit cards controlled by the Central Processor Card must be mounted in the first 6 rack frames.

The optional I/O PCB can be used to pass information from the Key Confirmation PCB in a Master Call Station to indicate which keys are currently active. It can also be used to communicate via a standard RS232 port with a computer.

SPECIFICATIONS

LBB I350 and LBB I370 range

SM40 DISTRIBUTION AND SURVEILLANCE SYSTEMS

5.1.3 SIGNAL GENERATOR CARD - SGC LBB I354/00

Main data

- Card in the Distribution Basic System
- Eurocard 10x22 cm with an 'ab' connector 2x32
- Test, chime and alarm tone generator
- Pre-programmed with over 70 signals
- Signals to be activated by the Central Processor Card

Correlation with other cards

Output: Matrix Card

Others: Central Processor Card

Max. number of cards in the system

8 Signal Generator Cards.

Operation

This card enables the user to select signals from a wide variety of tones and chimes and route them to the loudspeakers zones. The generator is controlled by a central processor and is pre-programmed with over 70 different signals, chimes, alarms and test tones. Any signal may be programmed to precede an announcement from a Call Station or may be used on its own, depending on its character, as an alarm or warning tone. The timer on the Central Processor Card can activate signals at specific times of the day or week.

The selection of the signal set is done by means of the jumper setting:

- | | |
|---------|---|
| Set I | Chime tones and alarm signals |
| Set II | Test signals |
| Set III | Chime tones and dedicated
German alarm signals |

Signals of set II are used during installation and for service purposes.

The volume level of the alarm signals and the other signals can be pre-adjusted separately.

The card can be recognised by the Central Processor Card via an 'address' accomplished by a jumper setting on the card.

A headphone may be connected to the 6.3 mm jack socket on the front of the card to hear the signals generated.

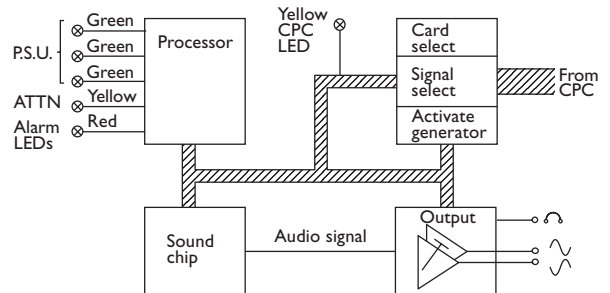

SPECIFICATIONS

LBB I350 and LBB I370 range

SM40 DISTRIBUTION AND SURVEILLANCE SYSTEMS

5.1.4 Matrix card - MC LBB I355/00

Main data

- Card in the Distribution Basic System
- Eurocard 10x22 cm with an 'ab' connector 2x32
- Matrix 4 in - 8 out (4x8)
- Additional cards can be installed to create up to a 16x64 matrix or a 32x32 matrix
- Switching is activated by Central Processor Card

Correlation with other cards

Input:	Input Card Signal Generator Card Signal Processor Card Automatic Volume Control Card Tone Control Card Digital Message Card Auxiliary
Output:	Signal Processor Card Tone Control Card Automatic Volume Control Card Direct to amplifier input Other Matrix Card
Others:	Central Processor Card

Max. number of cards in the system
Up to 32 cards may be connected together.

Operation

This Matrix Card enables inputs of the Distributions System to be routed to loudspeakers, located in geographical and/or functional zones, where people must be reached with background music, announcements and alarm

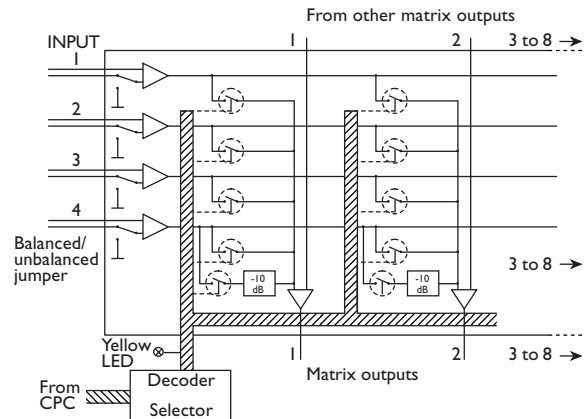

signals. Each Matrix Card switches the 4 line level audio inputs to any or all of its 8 outputs. Each input has a jumper for selecting balanced or unbalanced input signals.

The 4-th input of the Matrix Card has a programmable switch to attenuate the music signal by 10 dB when a Call Station is routed to the same loudspeaker zone.

In a larger matrix, addressing of the cards via jumper setting is necessary to create a large number of routing configurations. With the maximum of 32 Matrix Cards the following matrix configuration can be made.

16x64 matrix:	16 audio inputs to 64 audio outputs.
32x32 matrix:	32 audio inputs to 32 audio outputs.

5.1.5 Matrix termination board - MTB LBB I371/00

Main data

- Board in the Distribution Basic System
- 2 x 16 screw block connector
- 8 galvanic separation transformers can be mounted

Operation

A Matrix Termination Board can be used to suppress any small clicks which may occur when the outputs from the Matrix Card have been wired directly to an amplifier.

If encountering the distribution effects of an earth loop, up to 8 transformers may be mounted which isolate the earth (ground) of the input source equipment from that of the system.

5.1.6 SM40 Relay termination board LBB I379/00

Main data

- Board in the Distribution Basic System
- Installed in place of a normal termination board
- 2 x 16 screw block connector
- 8 relays to be activated by the make contacts of the eight relays on a Control Relay Card (CRC).
- Power supply for relays (+15V and -15V). Supplied internally from SM40 power supply.

Operation

This card will be used in an SM40 PA system to route the 100 volt audio output of a call and music amplifier to a maximum of eight loudspeaker zones. The card is therefore equipped with eight relays to be activated by the make contacts of the eight relays of a Control Relay Card (CRC) in an SM40 system which in turn can be activated by programming the system.

SPECIFICATIONS

LBB I350 and LBB I370 range

SM40 DISTRIBUTION AND SURVEILLANCE SYSTEMS

5.2 OPTIONAL CARDS

5.2.1 Tone control card - TCC LBB 1357/00

Main data

- Card for the Distribution System
- Eurocard 10x22 cm with an 'ab' connector 2x32
- 4 Individual tone control circuits
- Bass and treble correction from -10 to +10 dB
- Gain correction of +/- 10 dB
- Additional input selection for a splitter function

Correlation with other cards

Input: Matrix Card
 Input Card
 Auxiliary source

Output: Amplifier input
 Matrix Card

Max. number of cards in the system

No limitation.

Operation

This card can be very useful in situations where clarity of speech is vital and room acoustics make this difficult to attain.

Several applications are possible between the following cards, such as Input Cards outputs and Matrix Cards inputs; Matrix Cards outputs and Amplifier inputs.

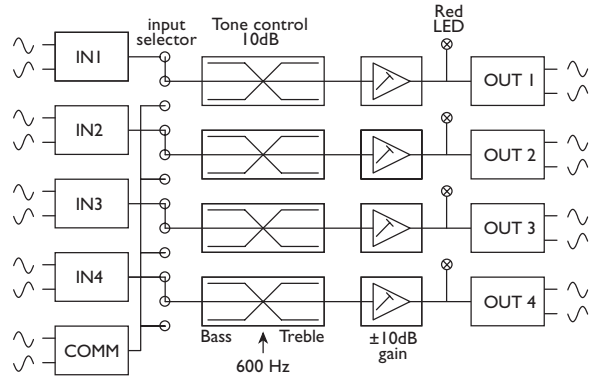

It has 4 independent tone control circuits, each having individual inputs and outputs. Each circuit has a separate bass and a treble amplification and attenuation to a maximum of 10 dB.

At the input of each circuit a screw-driver preset control is installed for adjusting the gain from -10 to +10 dB.

The card will accept a balanced or unbalanced source without any loss of sensitivity.

The card has an extra 'common' input which acts as a splitter and it allows the card to be fed by a single source instead of the 4 independent ones. This is particularly useful when several amplifiers are required to operate from 1 matrix output.

5.2.2 Signal processing card - SPC LBB 1358/00

Main data

- Card for the Distribution System
- Eurocard 10x22 cm with an 'ab' connector 2x32
- Filter combination channel with 3 parametric filters and adjustable -15 dB bass cut
- Compressor/limiter channel with ratio adjustable from 1:3 to 1:20
- Cascade of both channels possible

Correlation with other cards

Input: Matrix Card
 Input Card
 Auxiliary source
 Automatic Volume Control Card

Output: Amplifier input
 Matrix Card

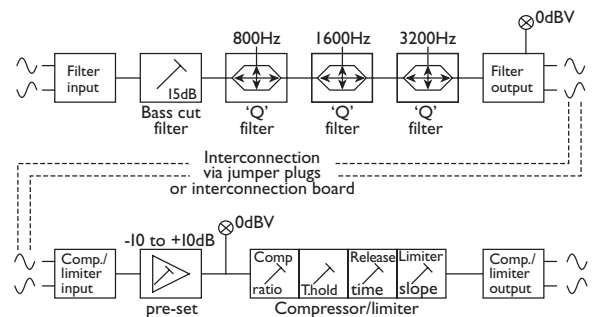

SPECIFICATIONS

LBB I350 and LBB I370 range

SM40 DISTRIBUTION AND SURVEILLANCE SYSTEMS

5.2.3 Automatic volume control card - AVC

LBB I359/00 - /09 - /21

Main data

- Card for the Distribution System
- Eurocard 10x22 cm with an 'ab' connector 2x32
- 2 Independent automatic volume control channels
- Sensing microphone required
- Automatic Noise Dependent Audio signal Processing (ANDAP) possible when combined with a Signal Processing Card

Correlation with other cards

Input: Sensing microphone
Matrix Card
Output: Amplifier input

General

The Automatic Volume Control card is available in three different versions:

- LBB I359/00 with an audio gain control range of 45 dB.
- LBB I359/09 with an audio gain control range of 9 dB.
- LBB I359/21 with an audio gain control range of 21 dB.

Operation

In environments such as football stadiums and airports, the background noise level fluctuates constantly. This card maintains the volume at a constant level above the background noise. It works by continually measuring and adjusting the volume.

The sensing microphone, in position in the listening environment concerned, provides the input for the card. The circuit samples the background noise level, except during calls so therefore the system gain is not reacting on his own calls. The sampling is blocked during the actual call signal, but resumes during speech pauses. The circuit continuously varies the output volume to compensate for changes in ambient noise level.

The card is normally placed after a Matrix Card, so that it can be used to effect two loudspeaker zones.

Each channel has preset potentiometers for the sense level (adjustment of the microphone sensitivity), the maximum boosted signal gain and the sense mute threshold level.

A red LED indicates the 0 dBV level output.

It is necessary to adjust the Automatic Volume Control Card on site to conform to the local conditions.

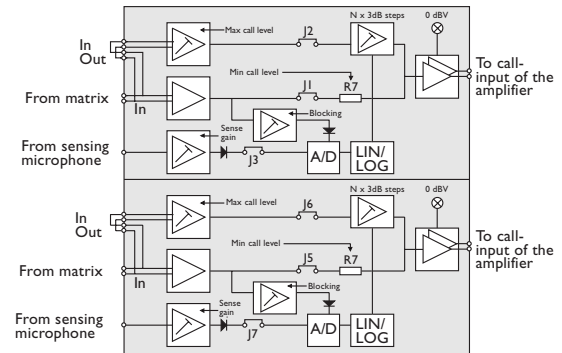

SPECIFICATIONS

LBB I350 and LBB I370 range

SM40 DISTRIBUTION AND SURVEILLANCE SYSTEMS

Max. number of cards in the system

Only limited by space and by the DC power supply available in the rack.

Operation

This card has a filter combination channel which functions as an equaliser to improve the intelligibility of spoken messages. It also has a compressor/limiter channel that evens out variations in signal level, making external inputs such as CD or cassette players ideal as background music sources.

The card may be used between music source output and Matrix Card input, Matrix Card output and Amplifier input, in combination with an Automatic Volume Control Card, etc.

The output of the filter channel may be fed into the input of the compressor/limiter channel and enables it to operate as one channel. Both channels are electrically balanced, but will accept unbalanced sources without any loss of sensitivity.

The filter combination channel has a bass cut and 3 parametric filters with fixed centre frequencies.

The gain of the bass cut-filter (high pass) is adjustable to a maximum of -15 dB at 100 Hz, sloping to 0 dB at 1,000 Hz.

The 3 parametric filters have centre frequencies fixed at 800, 1,600 and 3,200 kHz, but a simple modification allows these frequencies to be altered. The gain at the centre frequency of each band is adjustable to a maximum of +/- 10 dB. The 'Q' factor slope (width) of each band can be adjusted to match differing irregularities in the frequency curve.

A red LED indicates the 0 dBV level at the output.

The compressor limiter channel can be adjusted for a compression ratio from 1:3 to a maximum of 1:20. If the ratio is adjusted to 1:20, the channel will act as a limiter restricting the maximum output to a preset level. The attack time of the compressor is factory set at 1 msec, but the release time is adjustable between 40 ms and 4 seconds.

The preamplifier gain is adjustable to a maximum of 20 dB.

A red LED indicates the 0 dBV level at the input.

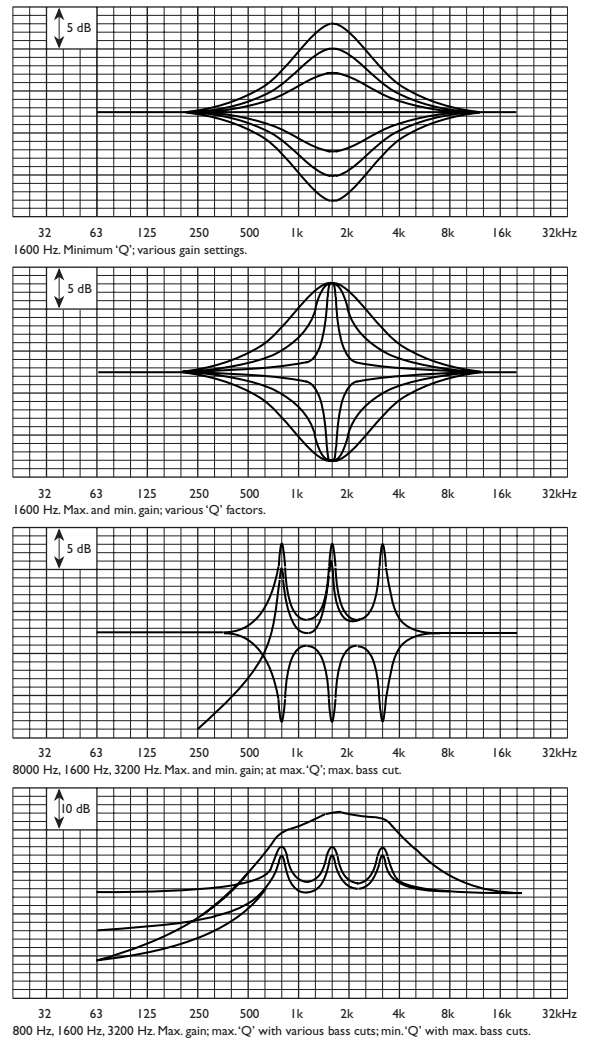

SPECIFICATIONS

LBB I350 and LBB I370 range

SM40 DISTRIBUTION AND SURVEILLANCE SYSTEMS

5.2.4 Automatic noise dependent audio signal processing - ANDAP

Main data

- Combining an Automatic Volume Control Card and a Signal Processor Card makes an ANDAP function possible.

Operation

The ANDAP function is useful wherever the system power is not sufficient to overcome environmental noise and thus ensure intelligibility. The ANDAP function boosts the high frequencies, and then compresses the dynamic range of the signal in order to project a clearly audible message without the need for extra power.

It operates as follows.

- Sampling the ambient (background) noise (see upper graph).
- Comparing it with the normal amplified speech signal (see upper graph). The dynamic range is shown by the upper line and lower line.
- When the noise level increases, the AVC function increases the level of the 'normal' speech signal to approx 90 dB (SPL) in the 300 to 800 Hz range (see middle graph).
- When the noise level increases to an extreme level, the most important frequencies for speech intelligibility are masked out, especially at the lower end of the dynamic range. To overcome this problem, ANDAP produces a 'processed' signal which has a reduced dynamic range and a shift in the maximum available loudness (90 dB) to between 500 Hz and 2 kHz (see lower graph). This has the effect of emphasising those frequencies which are most relevant to speech intelligibility.
- The amount of the 'processed' signal added to the original is determined by an integrated regulating facility.

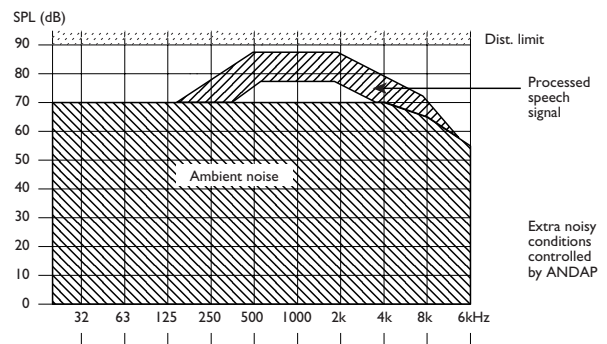
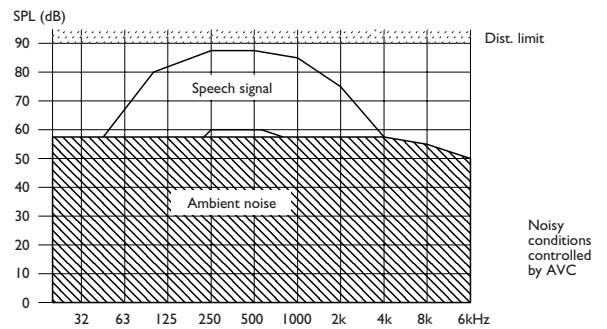
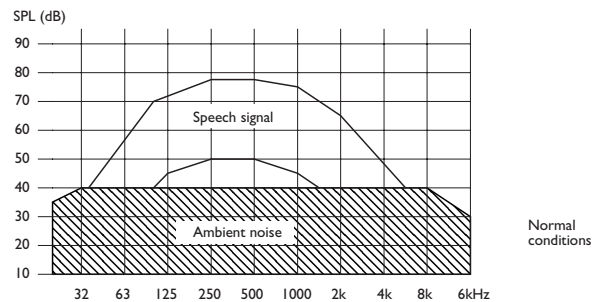
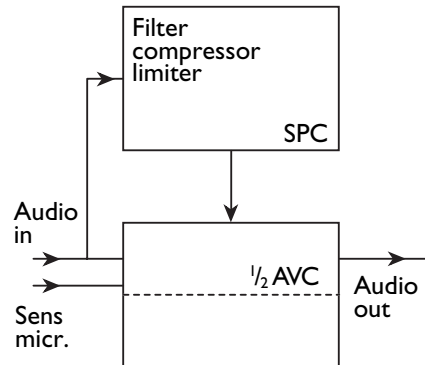

SPECIFICATIONS

LBB I350 and LBB I370 range

SM40 DISTRIBUTION AND SURVEILLANCE SYSTEMS

5.2.5 Digital message card - DMC LBB I378/00

Main data

- Optional card for the Distribution System
- Eurocard 10x22 cm with an 'ab' connector 2x32
- Digital recording of 7 individual messages during 65 seconds recording time
- Typical data retention time more than 30 days
- Stand-alone use possible for remote location recording
- Contains circuits for automatic gain and output volume control
- ADPCM technology
- Bandwidth up to 6 kHz

Correlation with other cards

Input: Call Station
Separate microphone
Output: Matrix Card
Others: Central Processor Card

Max. number of cards in the system

16 cards.

Operation

This unique card allows up to 7 individual messages to be recorded and played back as desired.

The recording is digitally stored in memory chips, ensuring that the quality will not deteriorate during the time that the message is stored in memory. When the power is switched off, the messages will remain intact in the memory for up to 30 days.

The maximum recording time is 65 seconds and messages of varying durations may be recorded, as long as the sum of the durations does not exceed the maximum recording time (65 seconds).

To record a message a separate microphone or a Call Station can be connected to the microphone input (5 pole, 180° DIN socket), which also provides the possibility of phantom powering.

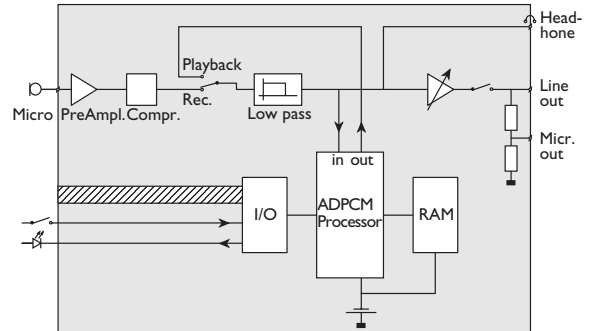

Since the record and monitor functions of the card are independent of the microprocessor in the system, the card may be taken out and transported to a remote location. With the aid of a suitable power supply and some extra switches, the card may be used to record the messages in a more suitable or convenient environment.

To play back the message(s) either alone or preceding a call, the system can be programmed so that play back will be activated by a Call Station or a User Key.

A headphone socket allows the recorded messages to be checked both during and after recording.

The limiter in the automatic gain control circuit ensures that the message is recorded at a fairly constant level. The output volume level is adjustable to the same values of those of the other system sources (attention signals, music sources, etc.).

Each card can be recognised by the Central Processor Card via an 'address' accomplished by jumper setting on the card.

SPECIFICATIONS

LBB I350 and LBB I370 range

SM40 DISTRIBUTION AND SURVEILLANCE SYSTEMS

5.2.6 I/O-PCB LBB I375/00

Main data

- To be mounted onto the Central Processor Card
- RS232 serial interface for communication link with a computer
- One wire asynchronous communication line for use in a Master Call Station

Correlation with other cards

Input: Central Processor Card
Output: Key Confirmation PCB computer, printer, etc.
Others: -

Operation

When mounted on the Central Processor Card in the Distribution System, this PCB allows communication via a standard RS232 serial interface with external computer equipment. It also controls the Key Confirmation Keys indicators in the Master Call Stations and acts in the same way as the Communication PCB.

To operate the communications link, a simple communication programme must be provided on the computer. A password is required to allow communication with the system.

Depending on the software applied, the computer can be used in the passive or active mode.

In the passive mode you can read or record the 'static' information (system configuration, sources connected) and the 'dynamic' information (call logging, auxiliary routing, failure information).

In the active mode you can use the computer for up/down loading of the programme, to program the matrix or even to operate as a Call Station or Master Call Station.

Remarks

The optional I/O-PCB set comprises:

- printed circuit board
- RS232 connector, fitted to a mounting bracket
- EPROM (version 5.3*) with Distribution System + I/O software
- All necessary cables, connectors and mounting parts
- Programming instructions
- All output signals are optically

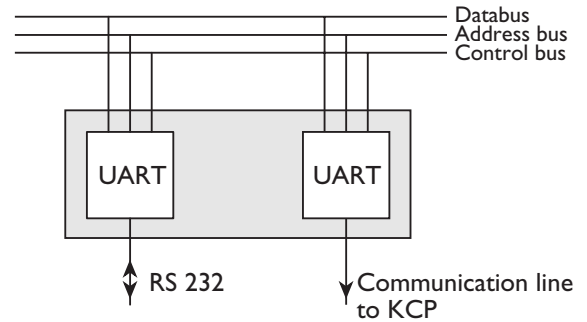

SPECIFICATIONS

LBB I350 and LBB I370 range

SM40 DISTRIBUTION AND SURVEILLANCE SYSTEMS

6. CARDS FOR THE SURVEILLANCE SYSTEM

6.1 SURVEILLANCE BASIC SYSTEM

6.1.1 Central processor card + I/O - CPC

Main data

- Card in the Surveillance Basic System
- Eurocard 10x22 cm with an 'ab' connector 2x32
- Microprocessor capability: 4,096 Monitoring devices to be scanned sequentially
80 Relays to be activated
- Error information to be sent to an external device via a standard RS232 port

Operation

This card is the heart of the Surveillance Basic System and the basic functions are as follows.

Scanning the Amplifier Surveillance Boards and Loudspeaker Surveillance Boards by sending sequentially +15V power to each of the 8 test lines of the Surveillance Switch Cards, which in turn sequentially send and receive data back to and from each board on each line. Priority scanning of the first and second zone is possible by programmable time intervals.

Translating the error data received from the various surveillance boards or from the external sensing devices and sending this information to the Display and Keyboard unit or via the RS232 port to a printer or external computer. Activating of the relays on the Control Relay Cards which in turn switch-on external warning devices (lights, buzzers, paging units, etc.).

Checking of the system hardware by continuously monitoring the system to check for errors, malfunctions or disconnections.

The presence of the Real time clock provides a continuous display of the date, hour and minutes and sends the date and time to a printer when an error occurs.

The user programmes the microprocessor via the Display and Keyboard. Having entered your password, the programme can be changed. For larger systems, extension frames LBB I360/30 can be used.

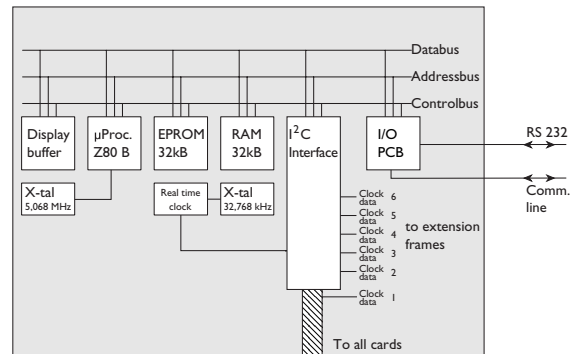

SPECIFICATIONS

LBB I350 and LBB I370 range

SM40 DISTRIBUTION AND SURVEILLANCE SYSTEMS

6.1.2 Pilot tone generator card - PGC LBB I369/00

Main data

- Card for the Surveillance Basic System
- Eurocard 10x22 cm with an 'ab' connector 2x32
- 20 kHz tone oscillator
- 16 independent balanced outputs

Correlation with other cards

Input: None

Output: Via Termination Boards to the amplifiers

Others: Continuously active and not controlled by the system

Max. number of cards in the system

Unlimited

Operations

The Surveillance System uses an ultrasonic 20 kHz pilot tone signal which is produced by this card. The tone signal is inserted at the specially developed test input on the Philips rack mounted amplifiers (e.g. SQ45) and then broadcasted to all the loudspeakers in the corresponding zones. The Surveillance System checks for the presence of this tone signal at various strategic points in the zone.

One single oscillator is used on every card to drive 16 electrically balanced outputs. One card can feed therefore 16 amplifiers/loudspeaker zones with pilot tone signals.

The card is not connected to any other card in the system. Only the required +15V and -15V will be supplied by the system.

To reduce power dissipation in amplifiers this card can operate with two possibilities:

- Continuous pilot-tone
- Burst pilot-tone (35 ms On, 260 ms Off)

These possibilities can be selected by a jumper located on the card. In addition the appropriate pilot-tone detection cards LBB I367 and LBB I368 are made suitable for this feature.

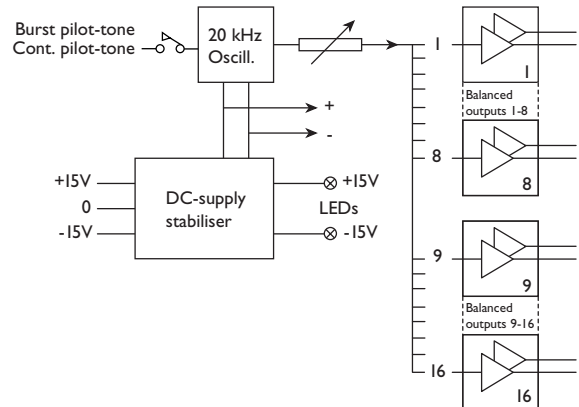

SPECIFICATIONS

LBB I350 and LBB I370 range

SM40 DISTRIBUTION AND SURVEILLANCE SYSTEMS

6.1.3 Surveillance switch card - SSC LBB I374/00

Main data

- Card for the Surveillance Basic System
- Eurocard 10x22 cm with an 'ab' connector 2x32
- 8 Individual 'test line' outputs
- Each test line supplies up to 128 monitoring devices with power and individual data communication
- 3 'Error' inputs

Correlation with other cards

Input: Amplifier Surveillance Board
Loudspeaker Surveillance Board

Output: Amplifier Surveillance Board
Loudspeaker Surveillance Board

Others: Central Processor Card

Max. number of cards in the system

4 Cards to scan up to 4096 units.

Operation

Since the Surveillance System is incapable of reading information from all of the monitoring devices at the same time, the card sequentially powers each string of Amplifier/Loudspeaker Surveillance Boards and receives data in turn from those boards.

The card is controlled by the Central Processor Card. It sends +15V power to each of the 8 lines in sequence. Because the +15V comes from a separate power supply, a galvanic separation with the system is present.

Up to 128 monitoring devices may be linked together on each test line.

The card has 3 external Error Inputs which can be activated by a closed contact. This could be a contact from a dedicated error relay on a Control Relay Card of the Distribution System, a smoke detector, a micro switch, etc.

The position of the card in the system is defined by an 'address' accomplished by jumper setting on the card.

Because of the internal wiring these cards must be fitted to the 4 positions on the far left hand site of the basic frame.

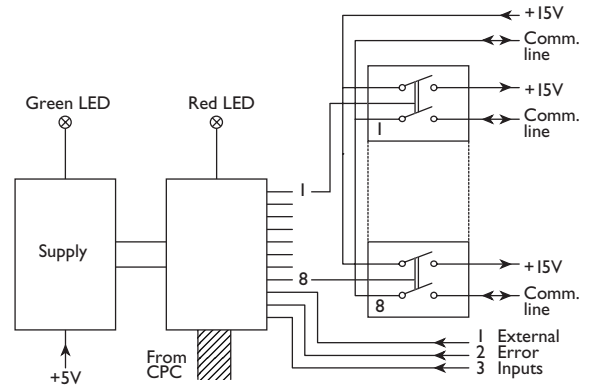

SPECIFICATIONS

LBB I350 and LBB I370 range

SM40 DISTRIBUTION AND SURVEILLANCE SYSTEMS

6.2 SEPARATE PRINTED CIRCUIT BOARDS

6.2.1 Loudspeaker surveillance board - LSB

LBB I367/00

Main data

- Separate board for the Surveillance System
- PCB dimensions 8x6 cm with solder-pin connections
- Monitoring the secondary side of the loudspeaker transformer and the voice coil of the loudspeaker
- Sensing the presence of the 20 kHz pilot signal

Correlation with other cards

Input: Surveillance Switch Card
Output: Surveillance Switch Card
Others: Central Processor Card

Max. number of cards in the system

In total more than 4,000 Loudspeaker Surveillance Boards (and/or Amplifier Surveillance Boards) can be connected via 4 Surveillance Switch Cards to the Central Processor Card.

Operation

This board monitors the continuity of the loudspeaker voice coil, the transformer, and the wiring to the amplifier by checking the presence of the 20 kHz pilot tone signal. It can easily be mounted inside a loudspeaker cabinet.

The board is wired in series between the secondary side of the loudspeaker transformer and the voice coil of the loudspeaker. In this position it is able to sense any dramatic changes in the current drawn by the loudspeaker at 20 kHz. When a fault occurs, the Central Processor Card detects this fault via the test line of the Surveillance Switch Card and an error message is sent to the system's display or printer.

In a 100V line system a wide range of variations are possible at the amplifier and the loudspeaker transformer output. Therefore on each board a test switch, a LED indicator and a potentiometer are provided to make local adjustment easy.

Each board has an 'address' which is obtained by setting the DIP-switches on the board and which allows the board for communication with the Central Processor Card.

A single standard 2 core 0.75 mm screened microphone cable carrying both data and power can be used to connect the boards over a maximum distance of 1,000 metres.

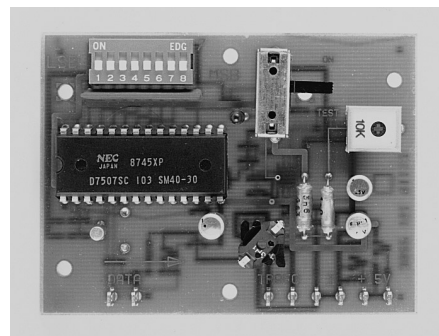
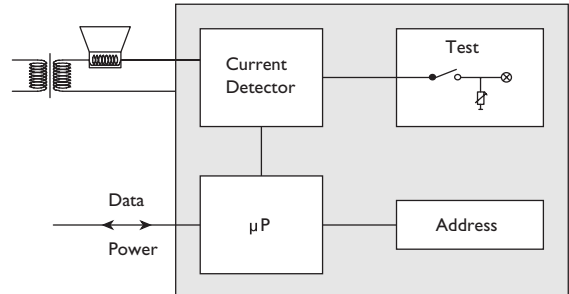

SPECIFICATIONS

LBB I350 and LBB I370 range

SM40 DISTRIBUTION AND SURVEILLANCE SYSTEMS

6.2.2 Amplifier surveillance board -ASB LBB I368/00

Main data

- Separate board for the Surveillance System
- PCB dimensions 6.5x7.2 cm with solder-pin connections to be used in the Phoenix mounting system
- Sensing the presence of the 20 kHz pilot tone at amplifiers output and on loudspeaker lines (100V system)
- Stand-alone applicable

Correlation with other cards

- Input: Pilot tone Generator Card
Surveillance Switch Card
100V sense-line or external contact
- Output: Surveillance Switch Card
External relay contacts
- Others: Central Processor Card

Max. number of cards in the system

128 boards may be linked together to 1 communication line

Operation

This board checks constantly the presence of the 20 kHz pilot signal on the 100 V loudspeaker line. There are two places where this check could be done. That is to say, directly behind the amplifier to monitor the amplifier output and on the loudspeaker input to monitor the line. The board can easily be mounted in the back of the amplifier rack.

The board can be triggered in two different ways. If you select the line input, the absence of the 20 kHz pilot signal will be detected. If the external input is used, the closed contact of any external device (smoke detector; micro switch, etc.) will trigger the board.

When the board has been triggered, it stops sending a message via the data test line to the Surveillance Switch Card and the Central Processor Card generates visual or printed information concerning the error.

A jumper is provided to allow the fitted relay with break and make contacts to be active or non-active. The relay output contacts can be used for activating warning devices or switching-on spare amplifiers (with external relays).

Each board has an 'address' which is obtained by setting the DIP-switches on the board and which allows the board for communication with the Central Processor Card.

A single standard 2 core 0.75 mm screened microphone cable carrying both data and power can be used for connecting the boards.

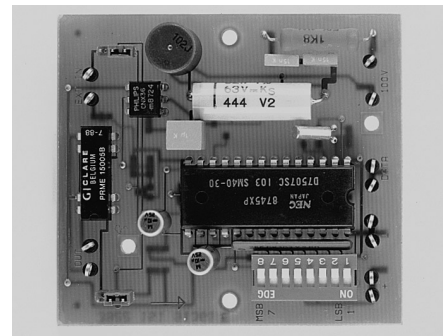
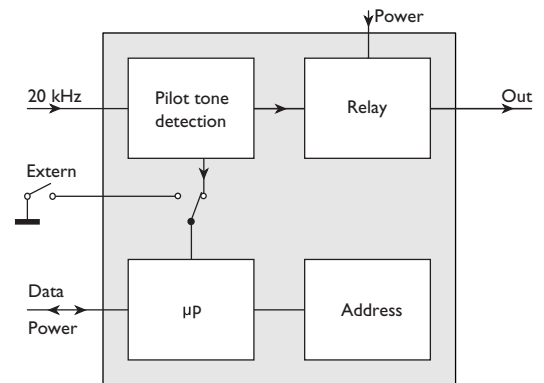

SPECIFICATIONS

LBB I350 and LBB I370 range

SM40 DISTRIBUTION AND SURVEILLANCE SYSTEMS

7. SPECIFICATION

7.1 GENERAL

Supply

Mains voltage : 220V (175 - 264V)
: 110V (90 - 140V) by strapping

Frequency : 47 - 440 Hz

Power consumption:

Distribution Basic System : 160VA (fully loaded frame)

Surveillance Basic System : 245VA (fully loaded frame)

Extension Frame : (depending on the number of cards)

Data retention time : >30 days

Safety standard : according to IEC 65

Environmental Conditions

Temperature : +5 to +55 °C

Mechanical

Dimensions (wxdxh)

rack frame : 483 x 335 x 133 mm (3U)

circuit cards : 1.6 x 220 x 100 mm

Weight

Distribution Basic System : 6.5 kg

Surveillance Basic System : 6.8 kg

Extension Frame : 5.5 kg

Terminations

Termination boards : screw connector blocks

Standard Call Station : DIN -3 pin male (180°)

7.2 CARD SUPPLY

Typical supply currents (mA)			
	+15V	-15V	+5V
Distribution System Cards			
Input Card	45	35	140
Signal Generator Card	45	35	140
Matrix Card	75	75	10
Control Relay Card	105	105	10
Tone Control Card	80	80	–
Call Station	15	130	–
Signal Processing Card	130	60	–
Automatic Volume Control Card	65	50	125
Digital Message Card	50		25
Distribution Basic System			
without optional cards	290	245	345
max. available power: PE 1141/52	1000	1000	4000
Surveillance System Cards			
Pilot Tone Generator Card	25	25	–
Surveillance Switch Card	*	–	12
Control Relay Card	105	105	10
Amplifier Surveillance Board	5	–	–
Loudspeaker Surveillance Board	3	–	–
Surveillance Basic System			
max. available power: PE 1141/52	1000	1000	4000
PE 1268/10	2000	–	–
Extension Frame			
max. available power: PE 1113/50	2000	2000	–

* separate power supply PE 1268/10 consumption depends on the number of ASB/LSB boards connected to the communication lines.

SPECIFICATIONS

LBB I350 and LBB I370 range

SM40 DISTRIBUTION AND SURVEILLANCE SYSTEMS

7.3 AUDIO SIGNAL DATA

	Distortion			Output	S/N Ratio		Crosstalk			Frequency Response	
	[%]			[dBV]	[dB]		[dB]			[Hz]	
	1 kHz @ output level			max	(A)	(flat)	5kHz	10kHz	15kHz	-3dB range	(0.5dB)
	+0dB	+10dB	+15dB								
Distribution Systems											
Input Card	<0.1	<0.2	<0.2	+20	>85	>81	>80	>74	>70	70-60,000	(20,000)
Signal Gen. Card	-	-	-	+0	>85	>81	-	-	-	-	-
Matrix Card											
- normal in	<0.1	<0.2	<0.5	+15	>84	>81	>85	>79	>75	30-60,000	(15,000)
- feed through	<0.1	<0.1	-	+15	>90	>87	-	-	-	30-60,000	(20,000)
Control Relay Card	-	-	-	-	-	-	-	-	-	-	-
Tone Control Card	<0.1	<0.1	-	+15	>88	>85	>85	-	>80	30-20,000	-
Call Station											
- 84 dB(SPL)	<0.1	-	-	+0	>64	>61	-	-	-	200-15,000	(12,500)
- 124 dB(SPL)	<0.5	-	-	+5	-	-	-	-	-	-	-
Optional Cards											
Signal Process. Card											
- compressor/ limiter	<0.1	-	-	+5	>78	>75	>85	-	>80	40-15,000	-
- filter	<0.1	<0.1	-	+15	>85	>83	>85	-	>80	30-20,000	-
Audio Volume Control Card	<0.5	-	-	-	>78	>75	>85	-	>80	40-20,000	-
Digital Message Card	<2	<4	-	-	>*	>*	-	-	-	320-6,000	-
Distribution Basic System											
(without optional cards)	<0.1	<0.2	<0.5	+15	>79	>76	>79	>73	>69	70-60,000	(15,000)
*to be specified											

SPECIFICATIONS

LBB I350 and LBB I370 range

SM40 DISTRIBUTION AND SURVEILLANCE SYSTEMS

7.4 CALL STATION CHARACTERISTICS

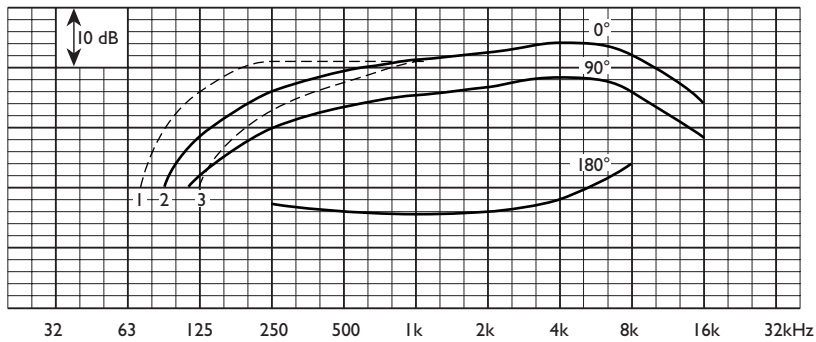
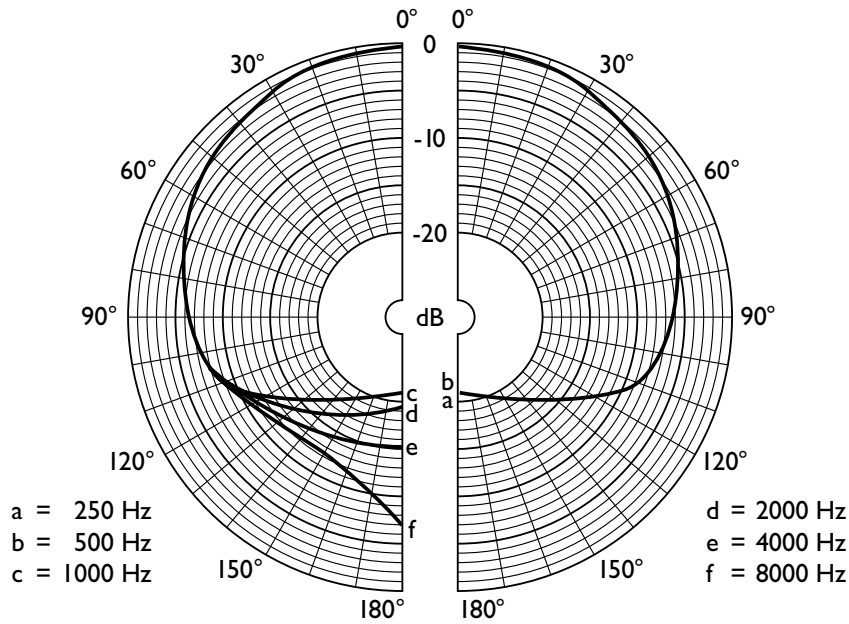

- Curve 1 = Bass cut reduced after service modification
- Curve 2 = Factory delivered bass cut
- Curve 3 = Bass cut increased after service modification

LBB I350 and LBB I370 range

SM40 DISTRIBUTION AND SURVEILLANCE SYSTEMS

7.5 AUDIO SIGNAL LEVEL DIAGRAM

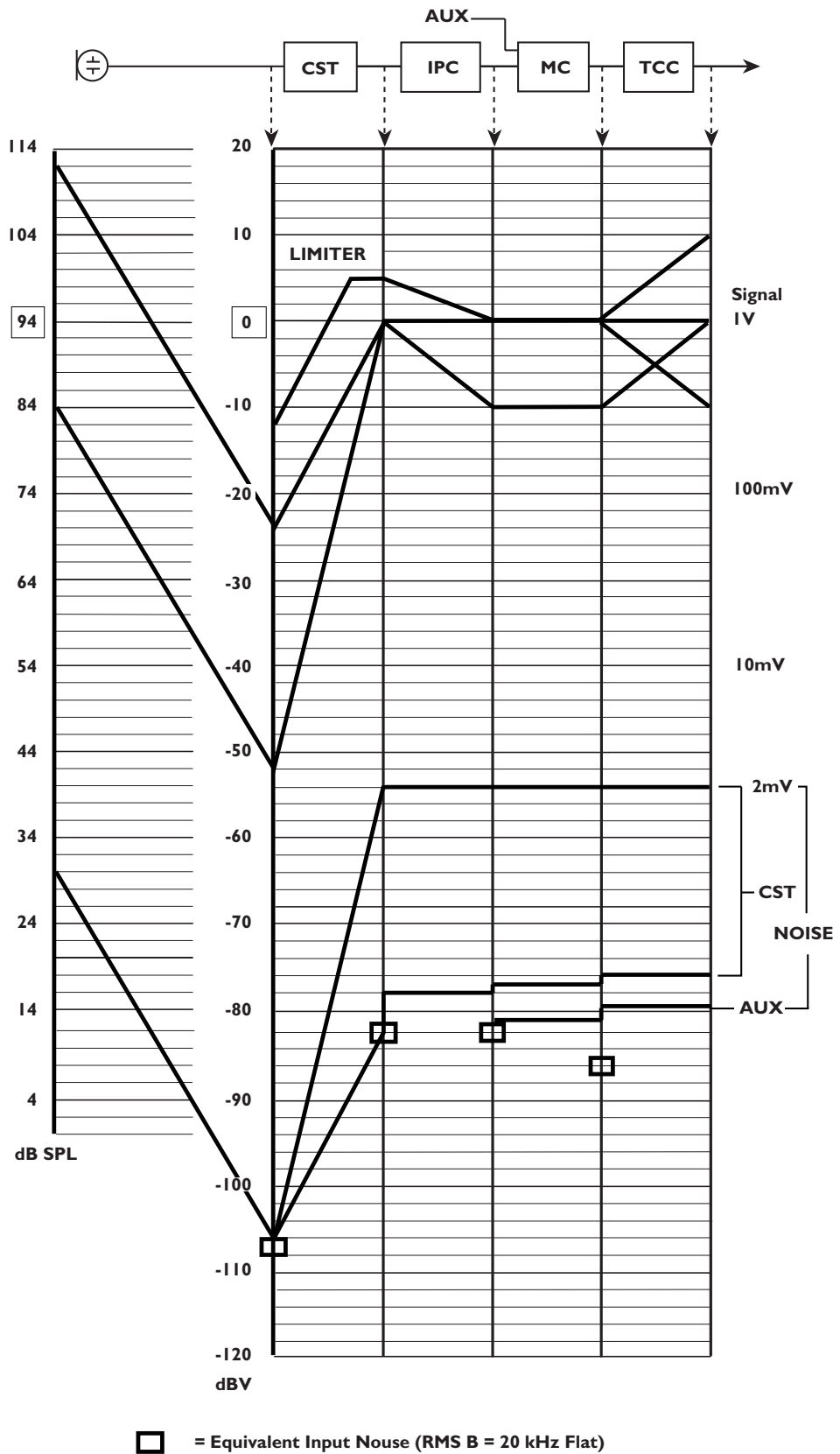

SPECIFICATIONS

LBB I350 and LBB I370 range

SM40 DISTRIBUTION AND SURVEILLANCE SYSTEMS



PHILIPS

Let's make things better.